

TABLE "A" RAFTER SPANS (DOUGLAS FIR #2 OR BETTER)		
SIZE	SPACING	SPAN
2 x 4 (e)	12" O.C.	9' - 10"
	16" O.C.	8' - 11"
4 x 4	24" O.C.	7' - 8"
	32" O.C.	*6' - 3"
2 x 6 (e)	12" O.C.	15' - 4"
	16" O.C.	13' - 9"
4 x 6	24" O.C.	11' - 3"
	32" O.C.	*9' - 7"
	12" O.C.	20' - 0"
4 x 8	16" O.C.	18' - 2"
	24" O.C.	14' - 10"
	32" O.C.	*12' - 8"
2 x 10 (e)	12" O.C.	20' - 0"
	16" O.C.	20' - 0"
	24" O.C.	18' - 11"
4 x 10	32" O.C.	*16' - 2"
	24" O.C.	10' - 0"
	32" O.C.	*9' - 3"
4 x 4	48" O.C.	*7' - 8"
	24" O.C.	15' - 11"
	32" O.C.	*13' - 9"
4 x 6	48" O.C.	*11' - 3"
	24" O.C.	20' - 0"
	32" O.C.	*18' - 2"
4 x 8	48" O.C.	*14' - 10"

TABLE "B" HEADER SIZE & SPANS (DOUGLAS FIR #2 OR BETTER)		
RAFTER SPAN	HEADER	
	SPAN	SIZE
UP TO 12' - 0"	8' - 0" MAX	4 x 6
	10' - 0" MAX	4 x 8
	12' - 0" MAX	4 x 10
	14' - 0" MAX	4 x 12
12' - 1" TO 20' - 0"	8' - 0" MAX	4 x 8
	10' - 0" MAX	4 x 10
	12' - 0" MAX	4 x 12
	14' - 0" MAX	4 x 14

TABLE "C" FOOTING SIZE
BASE ON 1,000 P.S.F. SOIL BEARING PRESSURE.
18" SQ. X 12" DEEP
18" SQ. X 12" DEEP
18" SQ. X 12" DEEP
18" SQ. X 12" DEEP
24" SQ. X 12" DEEP
24" SQ. X 12" DEEP
24" SQ. X 12" DEEP
24" SQ. X 12" DEEP

TABLE "D" LEDGER BOLTING
ALL LAG BOLTS SHALL HAVE 1/4" PRE-DRILLED HOLES (See Note b)
3/8" DIA. X 5" LONG AT 16" O.C. STAGGERED
(2) 3/8" DIA X 5" LONG AT 16" O.C.

**NOTES:**

- a. TWO 2X MEMBERS MAY BE SUBSTITUTED FOR ONE 4X HORIZONTAL FRAMING MEMBER, EXCEPT IN HIGH FIRE ZONE.
- b. LAG BOLTS MUST FULLY ENGAGE A WOOD STUD OR RIM JOIST AND BE PROVIDED WITH APPROPRIATE WASHERS. LAG BOLTS SHALL BE LOCATED A MINIMUM OF 1-1/2" FROM THE TOP OR BOTTOM OF THE LEDGER.
- c. NOT DESIGNED TO BE ENCLOSED - ADDITIONAL ENGINEERING ANALYSIS WILL BE REQUIRED IF ENCLOSED.
- d. SEE PAGE 2 OF 2 FOR CONSTRUCTION DETAILS.
- e. 2x JOISTS ARE NOT ALLOWED IN HIGH FIRE ZONE. PLEASE REFER TO 4x JOIST SCHEDULE FOR HIGH FIRE ZONE.
- f. PLYWOOD AND ROOFING MATERIAL USED IN HIGH FIRE ZONE SHALL BE CLASS "A".

**DISCLAIMER:**

ALTERNATE PATIO DESIGNS MAY BE POSSIBLE WHEN PROVIDED WITH AN ENGINEERED ANALYSIS. USE OF THIS CONVENTIONAL STANDARD DESIGN IS AT THE USER'S RISK AND CARRIES NO IMPLIED OR INFERRED GUARANTEE AGAINST FAILURE OR DEFECTS.

\* THIS SPACING AND SPAN IS FOR LATTICE PATIO COVERINGS ONLY.

	<b>COUNTY OF RIVERSIDE BUILDING DEPARTMENT</b>	
	<b>PATIO COVER STANDARD</b>	
(951) 955-1800	4080 LEMON ST, 9TH FL * P.O. Box 1629 *	
Fax (951) 955-1806	RIVERSIDE, CA 92501	
	04/2021	PAGE 1 OF 2

## KNEE BRACE DETAIL AT END POSTS

(REQUIRED WHEN RAFTER SPAN EXCEEDS 12 FT.)

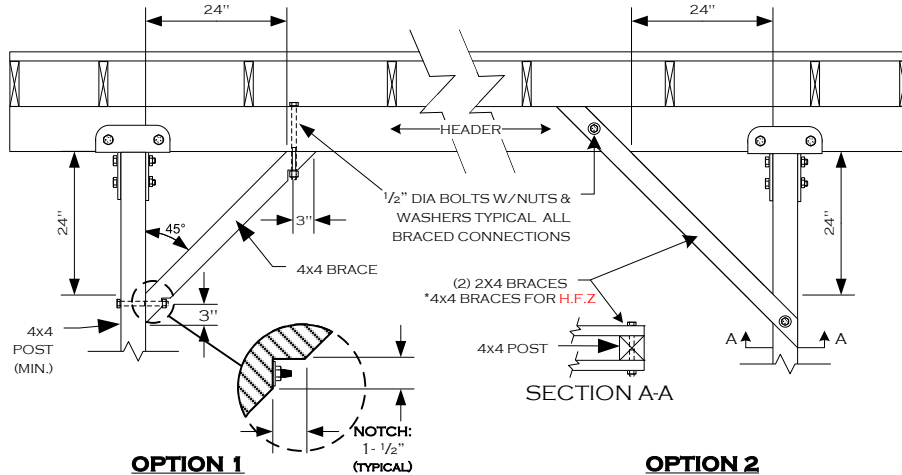

## LEDGER ATTACHMENT

### DETAIL

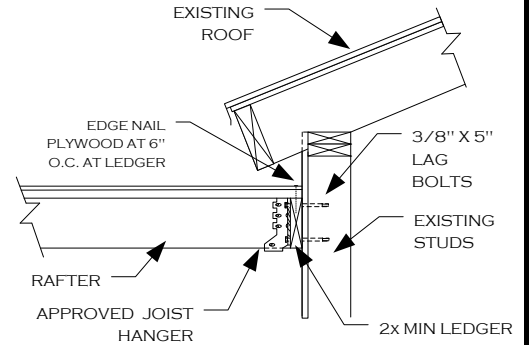

#### NOTES:

1. USE A CONTINUOUS 2x MIN LEDGER – SAME DEPTH AS RAFTER OR LARGER. ATTACH 2x BLOCKINGS TO 2x LEDGER WITH 10 D NAILS
2. SEE TABLE "D" FOR BOLTING REQUIREMENTS

## INVERTED HEADER DESIGN OPTION (LATTICE ONLY)

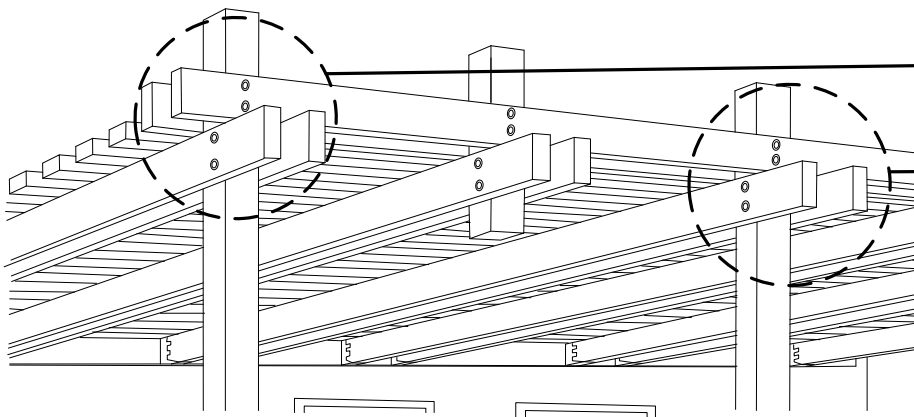

TWO 1/2" DIA. THRU-BOLTS (W/ WASHERS), PER CONNECTION AS SHOWN

FOR HEADERS OR RAFTERS- TWO 2X MEMBERS MAY BE SUBSTITUTED FOR ONE 4X MEMBER EXCEPT IN **HIGH FIRE ZONE**. SEE TABLES "A" & "B" FOR SPAN LIMITS

**NOTE:** KNEE BRACING REQUIRED WHEN RAFTER SPAN EXCEEDS 12 FEET.

## 2X FASCIA (OVERHANG) ATTACHMENT – LATTICE ONLY

### OPTION 1

### OPTION 2

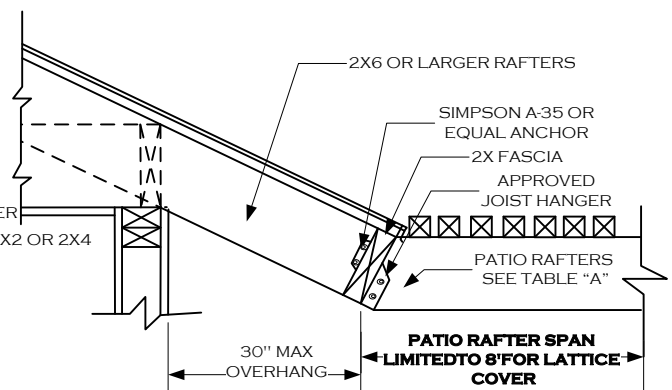
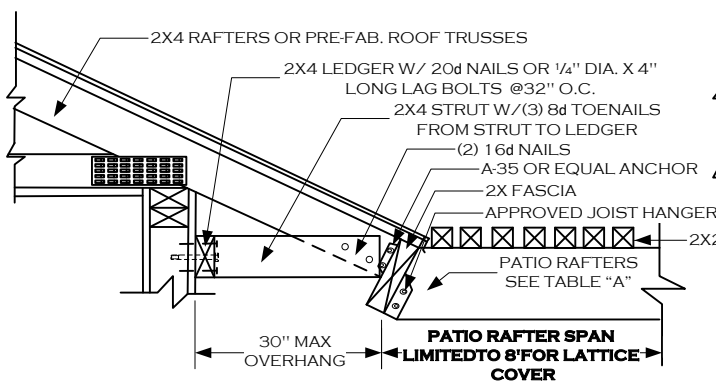

**NOTE:** VERIFY STRUCTURAL SOUNDNESS OF ROOF RAFTERS FOR DECAY OR TERMITE DAMAGE, AND REPLACE WITH LIKE MATERIALS AS NEEDED, AFTER CONSULTATION WITH THE BUILDING DEPARTMENT.



## COUNTY OF RIVERSIDE BUILDING DEPARTMENT

### PATIO COVER STANDARD

(951) 955-1800

4080 LEMON ST, 9TH FL \* P.O. Box 1629 \*

Fax (951) 955-1806

RIVERSIDE, CA 92501

04/2021

PAGE 2 OF 2