

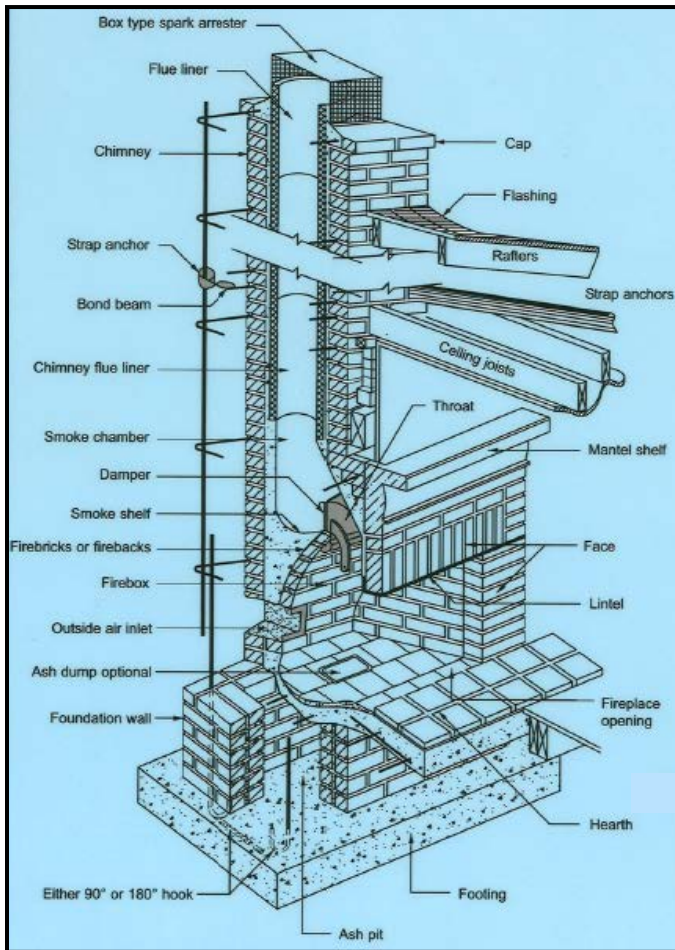

SAN JUAN CAPISTRANO BUILDING DEPARTMENT RESIDENTIAL MASONRY FIREPLACES AND CHIMNEYS

(*All work shall comply with 2016 California Building Code)

THE USE OF THIS FORM IS LIMITED TO PROJECTS LOCATED IN SEISMIC DESIGN CATEGORY D



PARTS OF A FIREPLACE AND CHIMNEY

Provide the following dimensions:

Height of fireplace measured from top of foundation to top of chimney: _____

Width of opening: _____

Height of opening: _____

Depth of firebox: _____

Width of jambs each side of opening: _____

Size of flue: _____

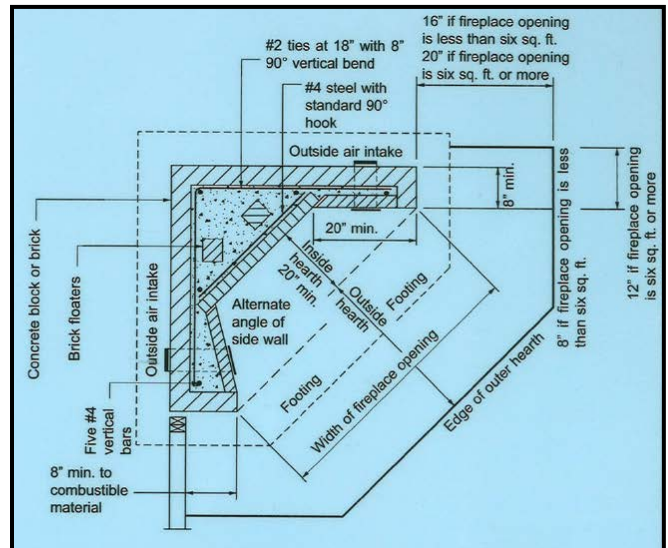

PLAN AT TOP OF HEARTH FOR CORNER FIREPLACE

MATERIAL REQUIREMENTS PER THE 2016 CALIFORNIA BUILDING CODE

Water shall be clean and potable.

Steel reinforcement conforming to ASTM A 615 Deformed and Plain Billet-Steel Bars for Concrete Reinforcement.

Firebrick conforming to ASTM C27 Fireclay and High-Alumina Refractory Brick or ASTM C 1261 Firebox Brick for Residential Fireplaces.

Brick conforming to ASTM C 62 Building Brick (Solid Masonry Units Made from Clay or Shale) or ASTM C 216 Facing Brick (Solid Masonry Units Made from Clay or Shale), Grade MW or SW.

Block conforming to ASTM C 90 Loadbearing Concrete Masonry Units.

Sand conforming to ASTM C 144 Aggregate for Masonry Mortar.

Portland Cement conforming to ASTM C 150 Portland Cement.

Firebox Mortar conforming to ASTM C 199 Standard Test Method for Pier Test Refractory Mortars.

Hydrated lime conforming to ASTM C 207 Hydrated Lime for Masonry Purposes, Type S.

Flue lining conforming to ASTM C 315 Clay Flue Liners and Chimney Pots.

MORTAR

Mortar for use in masonry construction shall conform to ASTM C and Articles 2.1 and 2.6 A of TMS 602/ACI 530.1/ASCE 6.

Mortar for firebox shall be medium-duty refractory mortar conforming to ASTM C 199 with 1/8" to 1/4" joints.

All cementitious materials and aggregates shall be mixed for a minimum period of three minutes with the amount of water required to produce the desired workability.

Retempering is permitted only by adding water within a basin formed of mortar and the mortar reworked into the water. Mortar which has become harsh and non-plastic shall not be retempered or used. Unused mortar shall be discarded within 2 1/2 hours after initial mixing.

GROUT

Grout shall conform to CBC 2103.3 or to ASTM C 476. Grout must be poured in a fluid state, 8 to 11 inch slump.

Grout shall be prevented from bonding with the flue liner so that the flue liner is free to move with thermal expansion.

CONSTRUCTION REQUIREMENTS

When the bricks are being laid, they shall be sufficiently damp, and the mortar sufficiently soft, so that the mortar will remain plastic to permit the units to be leveled and plumbed immediately after being laid without losing bond.

All masonry work shall be accurately executed and in conformity with the plans. No brick less than 1/2 length shall be used in exposed work. Head and bed joints shall be solidly filled with mortar and bricks shall be shoved into place.

In masonry chimney work, tempered mortar or grout shall fill the void between the flue lining and the masonry wall.

In fireplace construction, do not grout solidly behind the firebox wall. Slush loosely behind the firebox wall to allow for expansion of the firebox.

All joints exposed to the weather shall be tooled.

CHIMNEY REINFORCEMENT

For chimneys up to 40 inches wide, four No. 4 continuous vertical bars anchored in the foundation shall be placed in the concrete between wythes of solid masonry or within cells of hollow unit masonry grouted. For chimneys greater than 40 inches wide, two additional No. 4 vertical bars shall be provided for each additional 40 inches in width or fraction thereof.

Vertical reinforcement shall have a minimum cover of 1/2 inch of grout or mortar tempered to a pouring consistency. The maximum slope of vertical steel shall be 6 inches horizontal to 12 inches vertical.

Vertical reinforcement shall be placed enclosed within 1/4-inch ties, or other reinforcing of equivalent net cross-sectional area, spaced not to exceed 18 inches o.c. in concrete, or placed in the bed joints of unit masonry, at a minimum of every 18 inches of vertical height. Two such ties shall be provided at each bend in the vertical bars.

ADDITIONAL LOAD

Chimneys shall not support loads other than their own weight unless they are designed and constructed to support the additional load. Engineered plans, details, and structural calculations signed and stamped by a licensed architect or civil engineer must be submitted for approval.

SEISMIC ANCHORAGE OF CHIMNEY

Masonry chimneys and foundations shall be anchored at each floor, ceiling or roof line more than 6 feet above grade, except where constructed completely within the exterior walls.

Anchorage shall consist of two 3/16-inch by 1-inch straps embedded a minimum of 12 inches into the chimney. Straps shall be hooked around the outer bars and shall extend 6 inches beyond the bend. Each strap shall be fastened to a minimum of four joists with three 1/2-inch bolts.

Provide complying edge and end distances for all fasteners. Blocking between the rafters is required.

Where the joists do not head into the chimney, the anchor straps are connected to 2-inch by 4-inch ties crossing a minimum of four joists. The ties should be connected to each joist with three 16d nails. As an alternative to the 2-inch by 4-inch ties, the straps may be connected to the structural framework by three 1/2-inch bolts in an approved manner.

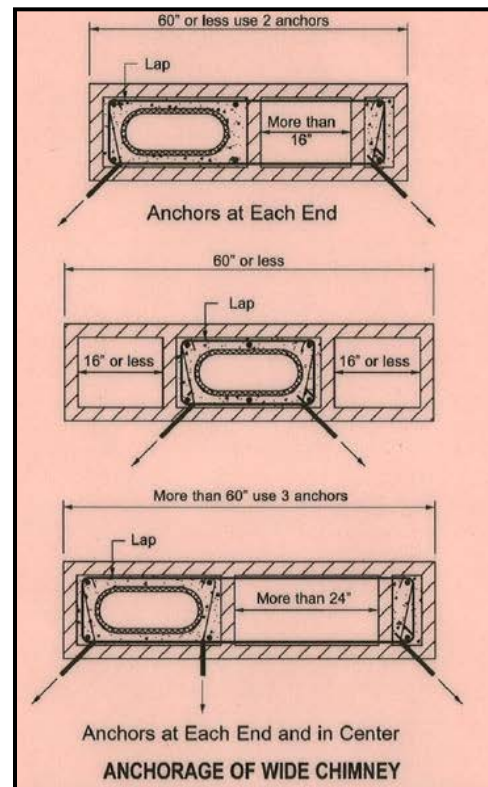
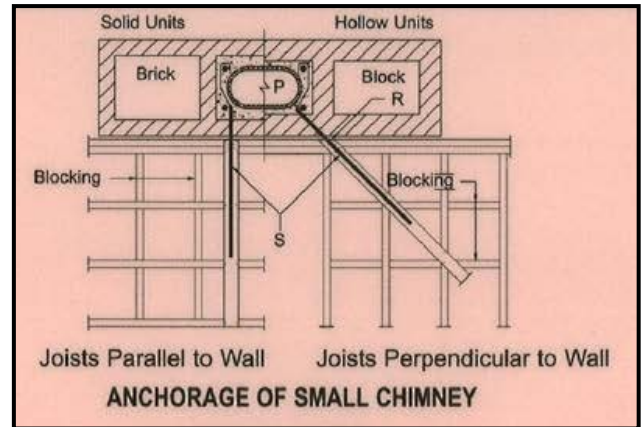

TERMINATION

Chimneys shall extend at least 2 feet higher than any portion of the building within 10 feet, but shall not be less than 3 feet above the highest point where the chimney passes through the roof.

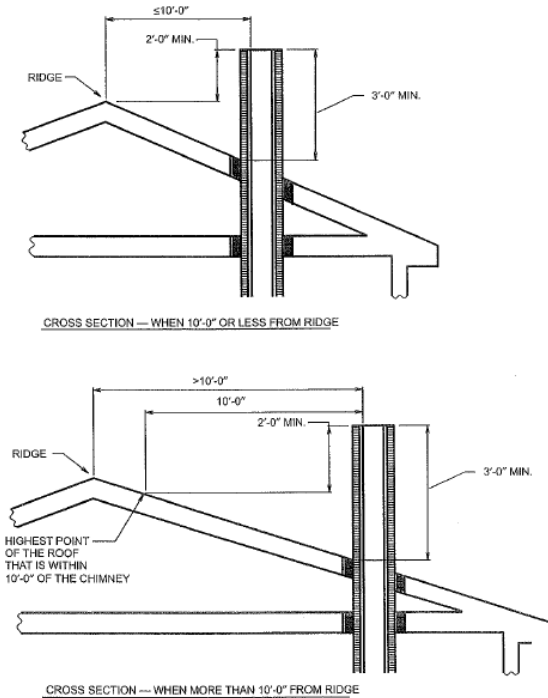

FIGURE 2113.16 FLUE SIZES FOR MASONRY CHIMNEYS

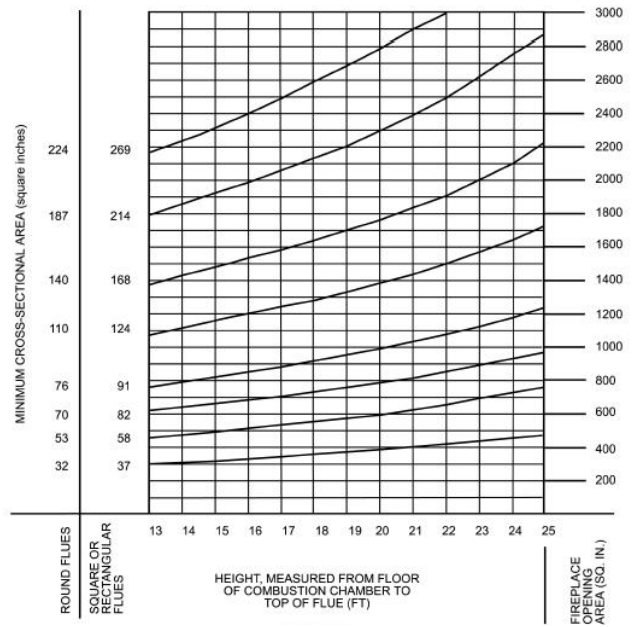

TABLE 2113.16 (1)
NET CROSS-SECTIONAL AREA OF ROUND FLUE SIZES

FLUE SIZE, INSIDE DIAMETER (inches)	CROSS-SECTIONAL AREA (square inches)
6	28
7	38
8	50
10	78
10 3/4	90
12	113
15	176
18	254

SPARK ARRESTORS

All chimneys attached to any appliance or fireplace that burns solid fuel shall be equipped with an approved spark arrestor. The spark arrestor shall meet all of the following requirements:

1. The net free area of the spark arrestor shall not be less than four times the net free area of the outlet of the chimney.
2. The spark arrestor screen shall have heat and corrosion resistance equivalent to 12-gage wire, 19-gage galvanized wire or 24-gage stainless steel.
3. Opening shall not permit the passage of spheres having a diameter larger than 1/2 inch and shall not block the passage of spheres having a diameter of less than 3/8 inch.
4. The spark arrestor shall be accessible for cleaning and the screen or chimney cap shall be removable to allow for cleaning of the chimney flue.

FLUE AREA

Round chimney flues shall have a minimum net cross-sectional area of at least 1/12 of the fireplace opening. Square chimney flues shall have a minimum net cross-sectional area of at least 1/10 of the fireplace opening. Rectangular chimney flues with an aspect ratio of 2 to 1 or more shall have a minimum net cross-sectional area of at least 1/8 of the fireplace opening.

The minimum net cross-sectional area of the flue shall be determined in accordance with CBC Figure 2113.16. A flue size providing at least the equivalent net cross-sectional area shall be used. Cross-sectional areas of clay flue linings are as provided in CBC Tables 2113.16(1) and 2113.16(2) or as provided by the manufacturer. The height of the chimney shall be measured from the firebox floor to the top of the flue.

TABLE 2113.16 (2)
NET CROSS-SECTIONAL AREA OF SQUARE AND RECTANGULAR FLUE SIZES

FLUE SIZE, OUTSIDE NOMINAL DIMENSIONS (inches)	CROSS-SECTIONAL AREA (square inches)
4.5 x 8.5	23
4.5 x 13	34
8 x 8	42
8.5 x 8.5	49
8 x 12	67
8.5 x 13	76
12 x 12	102
8.5 x 18	101
13 x 13	127
12 x 16	131
13 x 18	173
16 x 16	181
16 x 20	222
18 x 18	233
20 x 20	298
20 x 24	335
24 x 24	431

INLET

Inlets to masonry chimneys shall enter from the side. Inlets shall have a thimble of fireclay, rigid refractory material or metal that will prevent the connector from pulling out of the inlet or from extending beyond the wall of the liner.

CLEANOUT OPENINGS

Cleanout openings shall be provided within 6 inches of the base of each flue within every masonry chimney. The upper edge of the cleanout shall be located at least 6 inches below the lowest chimney inlet opening. The height of the opening shall be at least 6 inches. The cleanout shall be provided with a noncombustible cover.

Exceptions: Chimney flues serving masonry fireplaces, where cleaning is possible through the fireplace opening.

ENERGY REQUIREMENTS

Per the 2016 Building Energy Efficiency Standards

Masonry fireplaces shall be installed with all of the following:

- A. Closeable metal or glass doors covering the entire opening of the firebox.
- B. A combustion air intake to draw air from the outside of the building directly into the firebox, which is at least six square inches in area and is equipped with a readily accessible, operable, and tight-fitting damper or combustion-air control device.
Exception: An outside combustion-air intake is not required if the fireplace will be installed over concrete slab flooring and the fireplace will not be located on an exterior wall.
- C. A flue damper with readily accessible control.
Exception: When a gas log, log lighter or decorative gas appliance is installed in a fireplace, the flue damper shall be blocked open if required by the California Mechanical Code or the manufacturer's installation instructions.

Continuous burning pilot lights and the use of indoor air for cooling a firebox jacket, when the indoor air is vented to the outside of the building, are prohibited.

**2013 CALIFORNIA BUILDING CODE
SUMMARY OF REQUIREMENTS FOR MASONRY FIREPLACES AND CHIMNEYS
(Letters refer to Figure A: Fireplace and Chimney Details)**

ITEM	LETTER	REQUIREMENTS	CBC SECTION
Hearth and hearth extension thickness	A	4 inch minimum thickness for hearth, 2 inch minimum thickness for hearth extension	2111.10.1, 2111.10.2
Hearth extension (each side and opening)	B	8 inches for fireplace opening less than 6 square feet. 12 inches for fireplace opening greater than or equal to 6 square feet.	2111.11
Hearth extension (front of opening)	C	16 inches for fireplace opening less than 6 square feet. 20 inches for fireplace opening greater than or equal to 6 square feet.	2111.11
Hearth and hearth extension reinforcing	D	Reinforced to carry its own weight and all imposed loads	2111.10
Thickness of wall firebox	E	10 inches solid masonry or 8 inches where firebrick lining is used. Joints between firebricks no greater than ¼ inch.	2111.6
Distance from top of opening to throat	F	8 inches minimum	2111.8
Smoke chamber wall thickness dimensions	G	6 inches lined. 8 inches unlined. Not taller than opening width. Walls not inclined more than 45 degrees from vertical for prefabricated and smoke chamber linings for 30 degrees from vertical for corbelled masonry.	2111.9, 2111.9.1
Chimney Vertical reinforcing	H	Four No. 4 full-length bars for chimney up to 40 inches wide. Add two No. 4 bars for each additional 40 inches or fraction of width, or for each additional flue.	2111.4.1, 2113.3.1
Chimney Horizontal reinforcing	J	¼ inch ties at 18" o.c. and two ties at each bend in vertical steel.	2111.4.2, 2113.3.2
Bond beams	K	No specific requirements.	--
Fireplace lintel	L	Noncombustible material with 4 inch bearing length on each side of opening.	2111.8
Chimney walls with flue lining	M	4 inch thick solid masonry units or hollow masonry units grouted solid.	2113.10
Distances between adjacent flues	--	When two or more flues are located in the same chimney, masonry wythes shall be built between adjacent flue linings. The masonry wythes shall be at least 4 inches thick and bonded into the walls of the chimney.	2113.14
Effective flue area (based on area of fireplace opening and chimney)	P	See Figure 2113.16 and Tables 2113.16(1) and 2113.16(2)	2113.16
Clearances: From chimney From fireplace Combustible material Mantel and trim Above roof	R	2 inches interior, 1 inch exterior. 2 inches from front faces or sides; 4 inches from back faces. 12 inches minimum from firebox. 6 inches from fireplace opening. 3 feet above roof penetration, 2 feet above part of structure within 10 feet.	2113.19 2111.12 2111.12(3) 2111.12(4) 2113.9
Anchorage Strap Number Embedment into chimney Fasten to Bolts	S	3/16 inch by 1 inch. Two. 12 inches hooked around outer bar with 6 inch extension. 4 joists. Three ½ inch.	2111.5 2111.5 2111.5 2111.5 2111.5
Footing Thickness Width	T	12 inch minimum below finished grade. 6 inches each side of fireplace wall.	2111.3 2111.3

