

# CITY OF PERRIS

## DEVELOPMENT SERVICES DEPARTMENT PLANNING DIVISION

135 NORTH "D" STREET, PERRIS, CA. 92570-2200  
TEL: (951) 943-5003 FAX: (951) 943-8379

### LANDSCAPING DETAIL

1. CONCRETE CURB PER ENGINEERS PLAN
2. ROADWAY PER ENGINEERS PLAN
3. CONCRETE MOW STRIP, 2,500 P&W
4. #3 REBAR CONTINUOUS. LAP BARS 8" @ SPLICES & TIE
5. 1" TOOLED RADIUS
6. FINISH SURFACE OF MAINTENANCE BAND SHALL BE 3" ABOVE FINISH GRADE OF PLANTER AREA TO ALLOW FOR 3" OF WOOD MULCH.
7. AMENDED PLANTER SOIL PER SPECIFICATIONS.
8. 90% COMPACTED SUBGRADE

**NOTES:**

INSTALL 3/8" BITUMINOUS FELT EXPANSION JOINTS @ 20'-0" O.C. MAX. AND @ BEGINNING AND END OF RADIUS

PROVIDE 1" DP X 1/2" WD CONTROL JOINTS @ 5'-0" O.C.

SLOPE FINISH SURFACE OF 12" CONCRETE MAINTENANCE BAND TOWARD CENTER OF MEDIAN

COLOR SAMPLE OF CONCRETE ALONG WITH SAMPLE OF COBBLE REQUIRED FOR APPROVAL BY CITY OF PERRIS LANDSCAPE ARCHITECT PRIOR TO PURCHASE AND INSTALLATION.

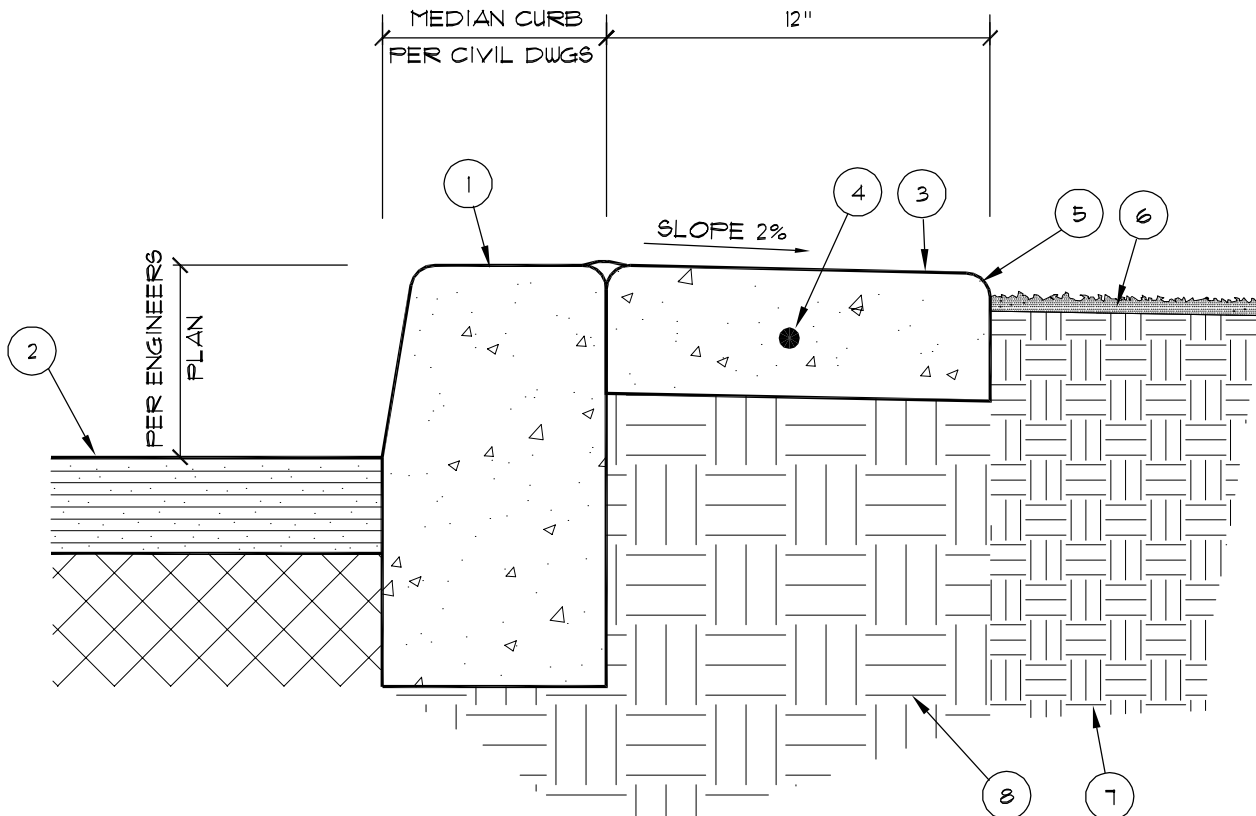

2/08

CITY OF PERRIS  
CITY LANDSCAPE ARCHITECT

*Ron Kammeyer*  
RON KAMMEYER

**SAFETY EDGE**

**L-1**

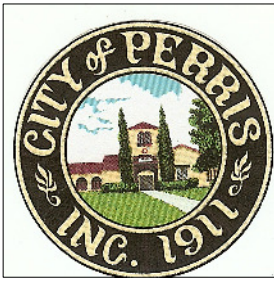

# CITY OF PERRIS

## DEVELOPMENT SERVICES DEPARTMENT PLANNING DIVISION

135 NORTH "D" STREET, PERRIS, CA. 92570-2200  
TEL: (951) 943-5003 FAX: (951) 943-8379

### LANDSCAPING DETAIL

1. FINISH GRADE
2. 1" MAX. BETWEEN TOP OF ADJACENT ROCKS
3. 1" - 1 1/2" TOP OF ROCK & MORTAR
4. 1 1/2" MAX. BETWEEN ROCKS AFTER MORTAR APPLICATION
5. ROCK, FLAT SIDE UP.
6. 1" - 1 1/2" DEPTH DRY APPLIED COLORED MORTAR.
7. CONCRETE CURB PER ENGINEERS PLANS.
8. 2500 PSI CONCRETE BASE, 3" MIN. BELOW BOTTOM OF LARGEST ROCK.
9. 90% COMPACTED SUBGRADE
10. 3" WOOD MULCH IN PLANTER AREA

**NOTES:**

ROCK BLANKET: COBBLE  
AVAILABLE FROM: SUPERIOR READYMIX  
OR APPROVED EQUAL.  
CONTACT: 951-658-1562  
SIZE: 4"-8"  
COLOR: PALM SPRINGS GOLD

NO EXPOSED MORTAR AT OUTSIDE EDGES

COLOR SAMPLE OF COBBLE AND MORTAR  
WITH COLOR SAMPLE OF CONCRETE REQUIRED  
FOR SUBMITTAL AND APPROVAL BY CITY OF  
PERRIS LANDSCAPE ARCHITECT PRIOR TO  
PURCHASE AND INSTALLATION.

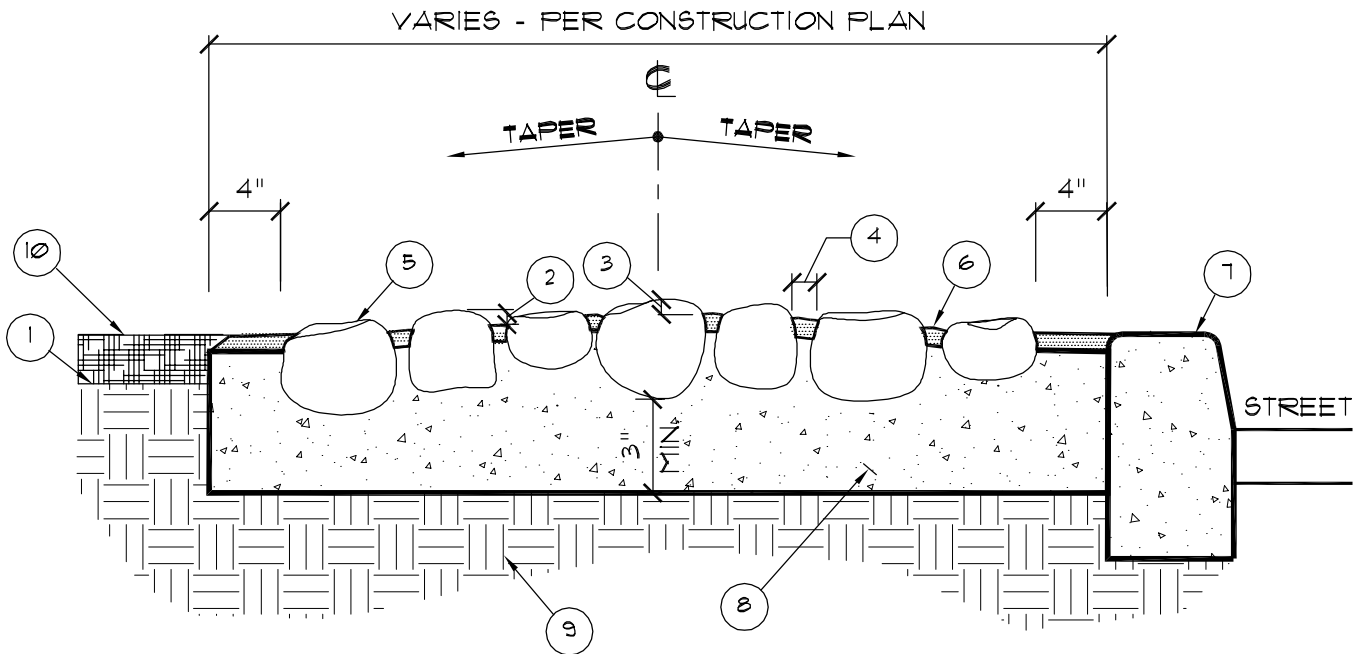

12/07

CITY OF PERRIS  
CITY LANDSCAPE ARCHITECT

*Ron Kammeier*  
RON KAMMEIER

ROCK BED AT MEDIAN NOSE

L-2

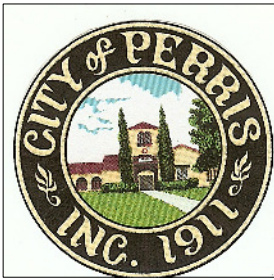

# CITY OF PERRIS

DEVELOPMENT SERVICES DEPARTMENT  
PLANNING DIVISION

135 NORTH "D" STREET, PERRIS, CA. 92570-2200  
TEL: (951) 943-5003 FAX(951) 943-8379

## LANDSCAPING DETAIL

- 1 FINISH GRADE FOR PLANTER/TURF
- 2 BOULDER LOCATION AND SIZE PER PLAN
- 3 UNDISTURBED SOIL/AMENDED SOIL

NOTE:

1. BOULDER SIZE AND TYPE SHALL BE APPROVED PRIOR TO PURCHASE OF MATERIAL.
2. ALL BOULDER LOCATIONS SHALL BE APPROVED BY CITY LANDSCAPE ARCHITECT

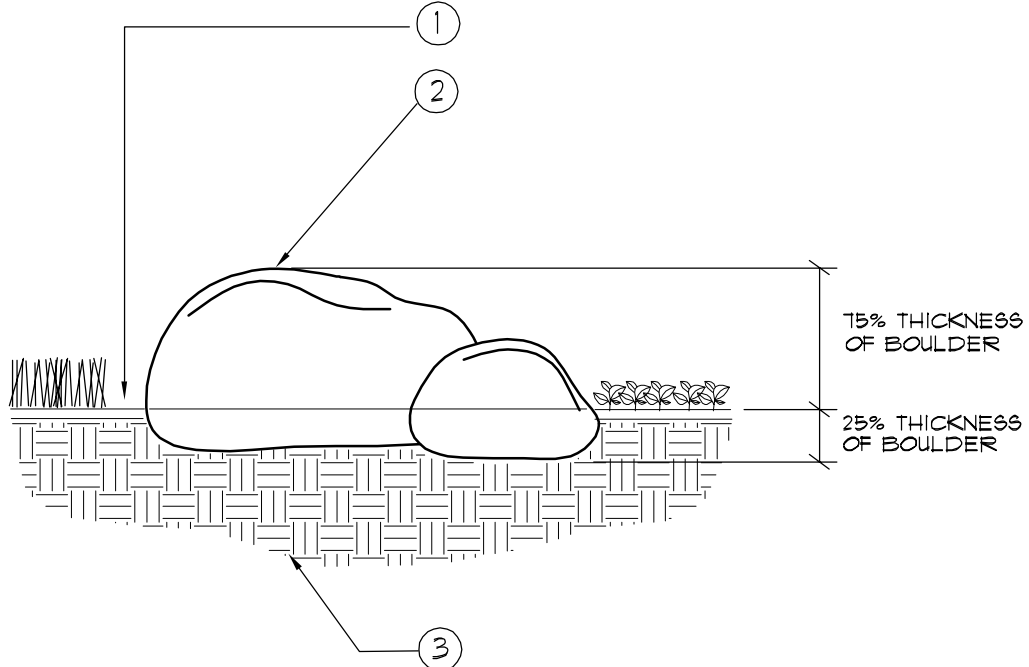

12/07

CITY OF PERRIS  
CITY LANDSCAPE ARCHITECT

*Ron Kammeier*  
RON KAMMEYER

# BOULDER PLACEMENT

# L-3

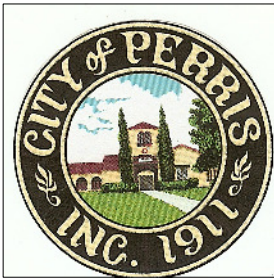

# CITY OF PERRIS

DEVELOPMENT SERVICES DEPARTMENT  
PLANNING DIVISION

135 NORTH "D" STREET, PERRIS, CA. 92570-2200  
TEL: (951) 943-5003 FAX(951) 943-8379

## LANDSCAPING DETAIL

### NOTES:

1. GROUND COVER MAY BE PLANTED THROUGH THE FABRIC
2. THE FABRIC SHALL BE INSTALLED ON GROUND A MINIMUM OF 48 HOURS PRIOR TO PLANTING TO ALLOW FABRIC TO SETTLE.
3. HOLES FOR PLANTING SHALL BE MADE WITH SHARP KNIVES OR SHEARS.
4. FABRIC IS TO BE FASTENED USING NO. 11 GAUGE WIRE, "U" SHAPED WITH 1" CROWN AND LESS 12" IN LENGTH OR PREFABRICATED STAPLES.
5. INSTALLATION PER MANUFACTURERS SPECIFICATIONS.

DOUBLE LAP JOINT.  
MIN. 4" OVERLAP AT THE  
SEAMS WITH DOUBLE ROW  
OF STAPLES

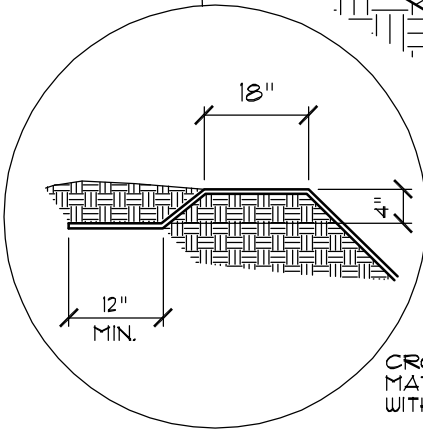
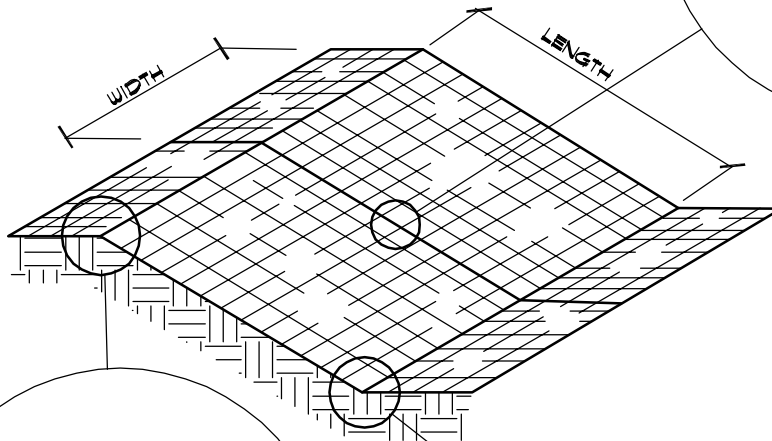
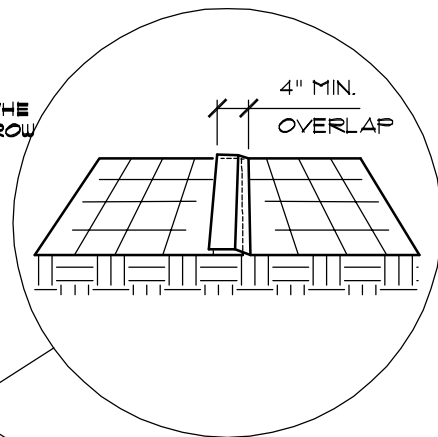

CROWN ANCHOR TRENCH  
MATERIAL SHALL BE COVERED  
WITH SOIL AND TAMPED.

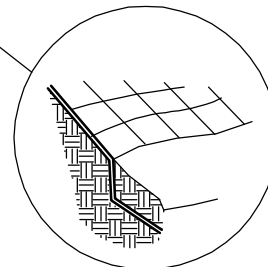

TOE ANCHOR TRENCH

2/08

CITY OF PERRIS  
CITY LANDSCAPE ARCHITECT

*Ron Kammeier*  
RON KAMMEYER

# EROSION CONTROL NETTING

# L-5

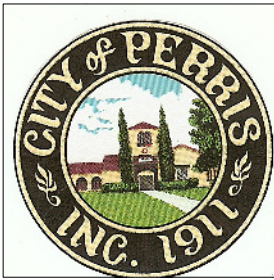

# CITY OF PERRIS

DEVELOPMENT SERVICES DEPARTMENT  
PLANNING DIVISION

135 NORTH "D" STREET, PERRIS, CA. 92570-2200  
TEL: (951) 943-5003 FAX(951) 943-8379

## LANDSCAPING DETAIL

### NOTES:

1. ALL TABLES AND BENCHES MUST HAVE A 4" THICK MIN. CONCRETE PAD

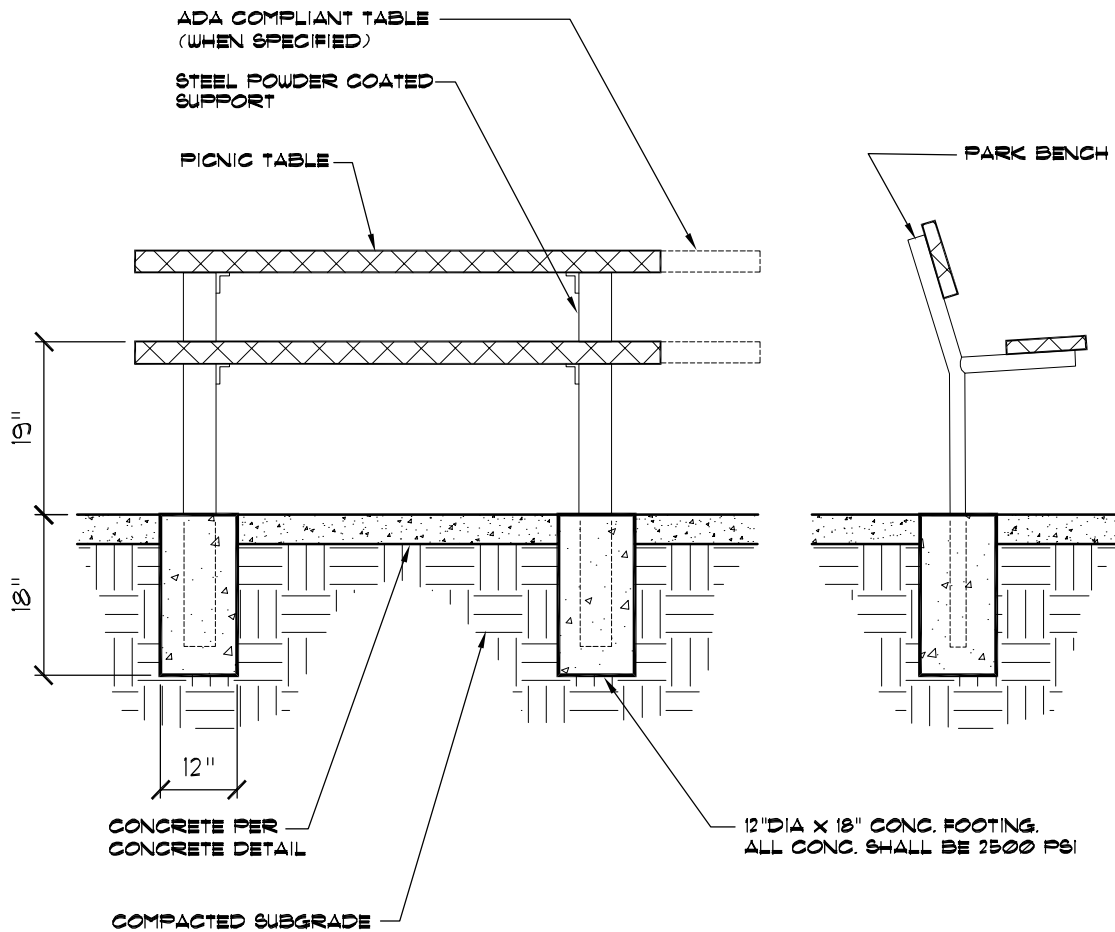

2/08

CITY OF PERRIS  
CITY LANDSCAPE ARCHITECT

*Ron Kammeier*  
RON KAMMEYER

## PARK BENCH/TABLE

## L-6

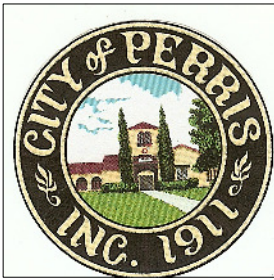

# CITY OF PERRIS

DEVELOPMENT SERVICES DEPARTMENT  
PLANNING DIVISION

135 NORTH "D" STREET, PERRIS, CA. 92570-2200  
TEL: (951) 943-5003 FAX(951) 943-8379

## LANDSCAPING DETAIL

### NOTES:

1. ALL RECEPTACLES MUST HAVE A 4" THICK MIN. CONCRETE PAD

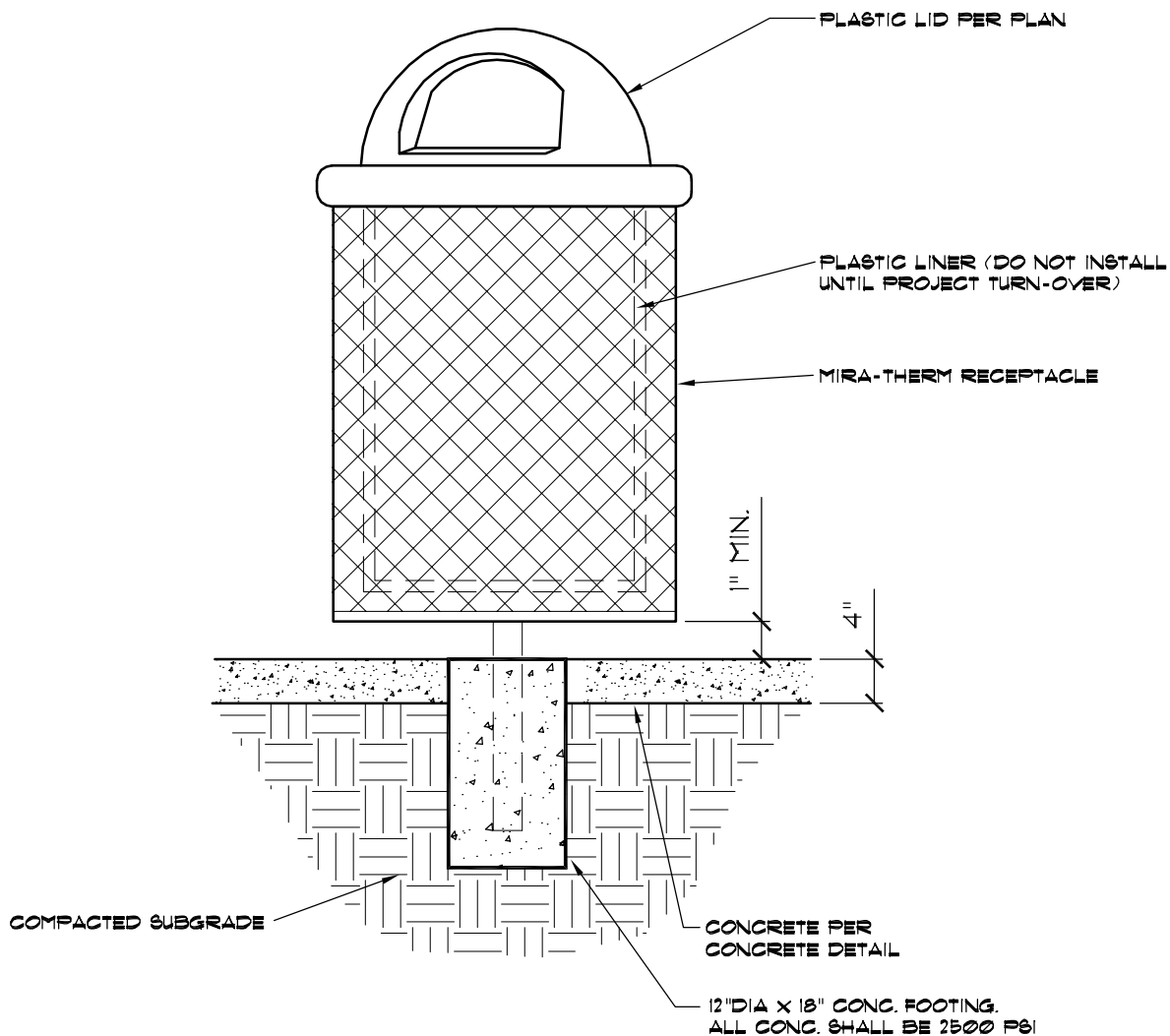

2/08

CITY OF PERRIS  
CITY LANDSCAPE ARCHITECT

*Ron Kammeier*  
RON KAMMEYER

# TRASH RECEPTACLE

# L-7

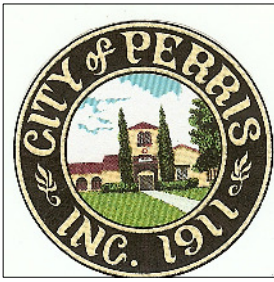

# CITY OF PERRIS

DEVELOPMENT SERVICES DEPARTMENT  
PLANNING DIVISION

135 NORTH "D" STREET, PERRIS, CA. 92570-2200  
TEL: (951) 943-5003 FAX(951) 943-8379

## LANDSCAPING DETAIL

### NOTES

1. INSTALL DOMESTIC WATER SUPPLY PER PLAN & LOCAL CODES
2. INSTALL DRAIN SUMP AND WASTE SUPPLY PER DRAIN SUMP DETAIL.

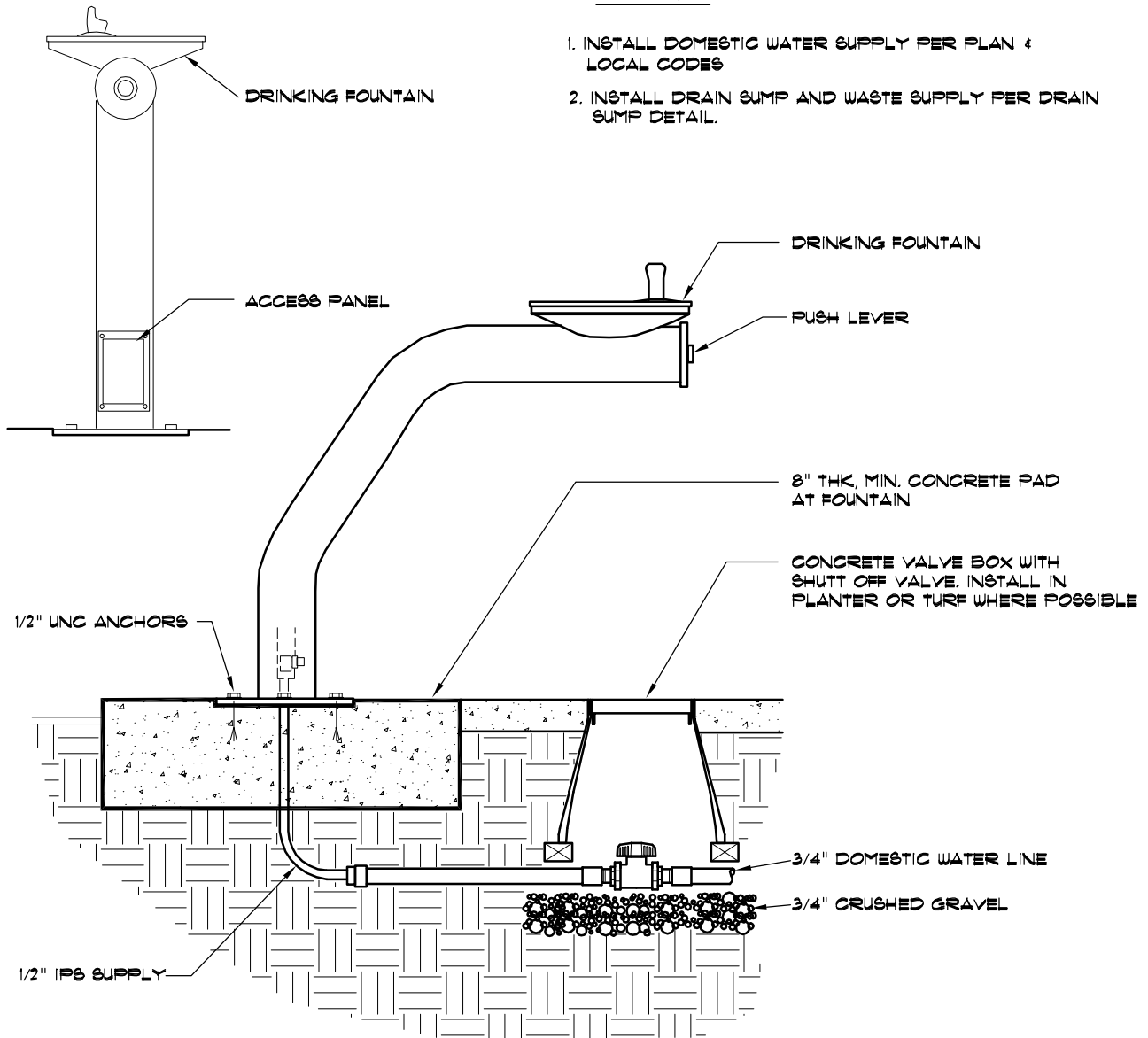

2/08

CITY OF PERRIS  
CITY LANDSCAPE ARCHITECT

*Ron Kammeier*  
RON KAMMEYER

## DRINKING FOUNTAIN

## L-8

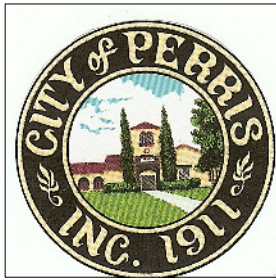

# CITY OF PERRIS

DEVELOPMENT SERVICES DEPARTMENT  
PLANNING DIVISION

135 NORTH "D" STREET, PERRIS, CA. 92570-2200  
TEL: (951) 943-5003 FAX(951) 943-8379

## LANDSCAPING DETAIL

### NOTE

INSTALL DOMESTIC WATER SUPPLY PER PLAN,  
LOCAL CODES AND MANUFACTURER'S SPECIFICATIONS

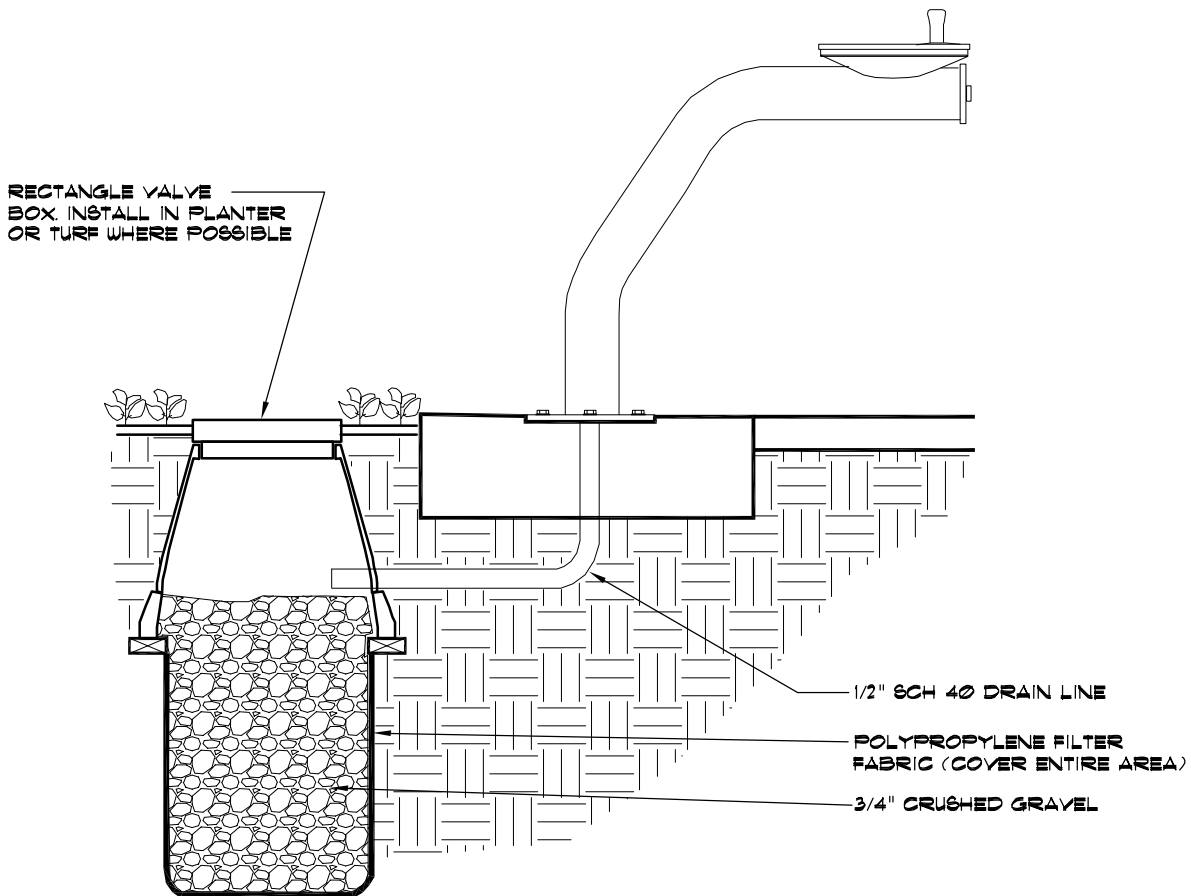

2/08

CITY OF PERRIS  
CITY LANDSCAPE ARCHITECT

*Ron Kammeier*  
RON KAMMEYER

## DRINKING FOUNTAIN SUMP

## L-9



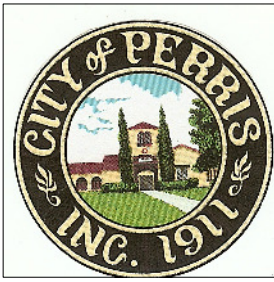

# CITY OF PERRIS

## DEVELOPMENT SERVICES DEPARTMENT PLANNING DIVISION

135 NORTH "D" STREET, PERRIS, CA. 92570-2200  
TEL: (951) 943-5003 FAX(951) 943-8379

### LANDSCAPING DETAIL

#### NOTES:

1. ALL CONCRETE SHALL HAVE A CROSS SLOPE OF 2% MAX.
2. PROVIDE 3/8" FELT EXPANSION JOINTS W/ MASTIC SEALANT WHEN CONCRETE JOINS WITH A BLOCK WALL OR OTHER STRUCTURE.
3. ALL CONCRETE MUST COMPLY WITH ADA REGULATIONS
5. ALL CONCRETE MUST COMPLY WITH ADA REGULATIONS.

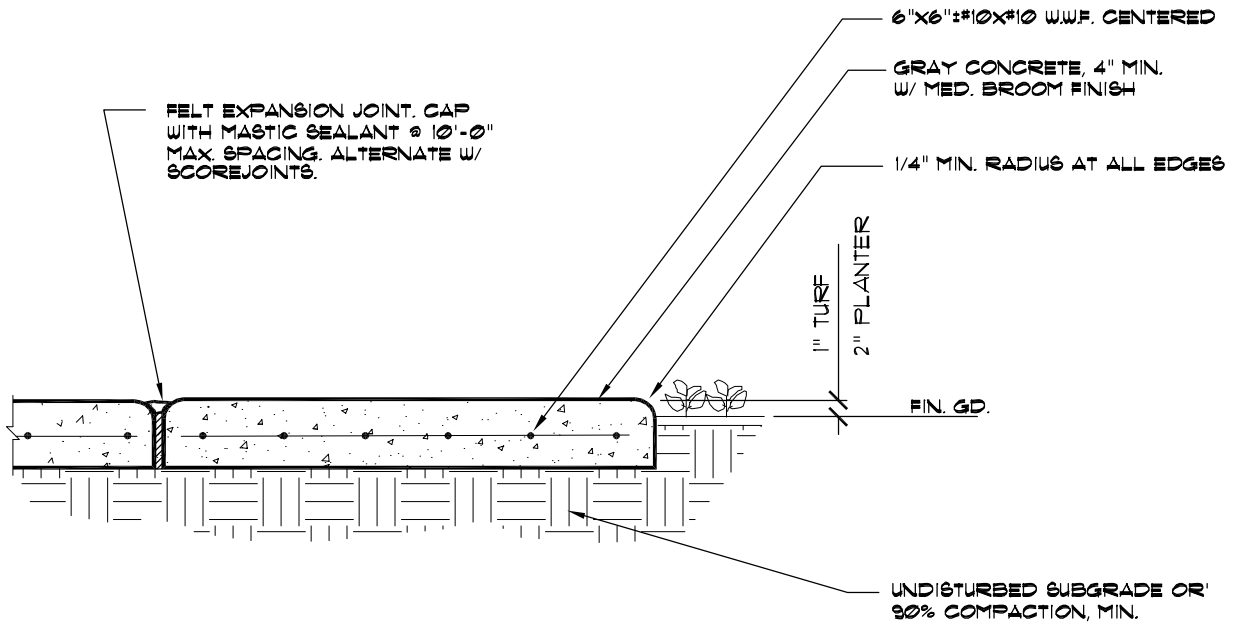

2/08

CITY OF PERRIS  
CITY LANDSCAPE ARCHITECT

  
RON KAMMEIER

## CONCRETE FLATWORK

## L-10

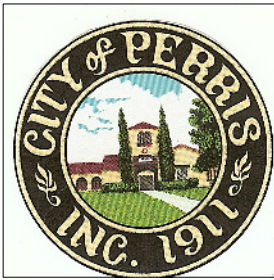

# CITY OF PERRIS

## DEVELOPMENT SERVICES DEPARTMENT PLANNING DIVISION

135 NORTH "D" STREET, PERRIS, CA. 92570-2200  
TEL: (951) 943-5003 FAX(951) 943-8379

### LANDSCAPING DETAIL

#### NOTES:

1. SUBGRADE FOR WOOD FIBER SHALL SLOPE TO SUMP DRAINS PER PLAN FOR WATER RUN OFF.
2. PROVIDE 1/2" MIN. RADIUS AT CONCRETE EDGE.
3. WOOD FIBER SAMPLE MUST BE SUBMITTED FOR APPROVAL TO OWNERS REPRESENTATIVE PRIOR TO PURCHASE OF MATERIAL.
4. PROVIDE A CONCRETE ADA ACCESS RAMP PER ADA REGULATIONS
5. PROVIDE SAND IN LIEU OF WOOD FIBER FOR PLAYGROUNDS FOR ANY AREA WITHIN A DETENTION BASIN.

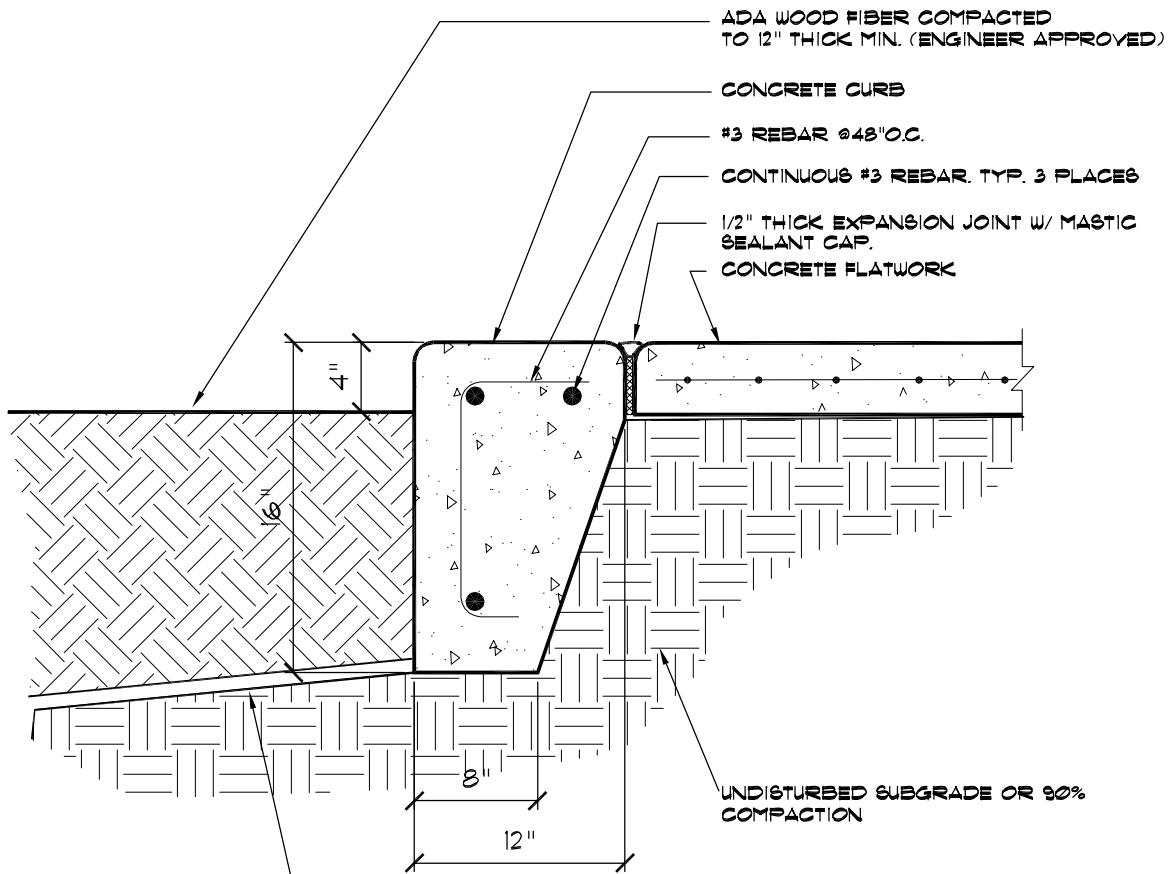

POLYPROPYLENE FILTER FABRIC  
COVER ENTIRE AREA.

2/08

CITY OF PERRIS  
CITY LANDSCAPE ARCHITECT

*Ron Kammeier*  
RON KAMMEYER

## PLAYGROUND CURB

## L-11

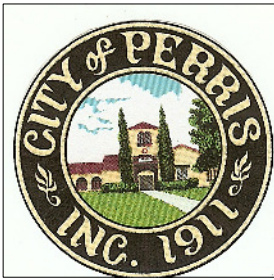

# CITY OF PERRIS

DEVELOPMENT SERVICES DEPARTMENT  
PLANNING DIVISION

135 NORTH "D" STREET, PERRIS, CA. 92570-2200  
TEL: (951) 943-5003 FAX(951) 943-8379

## LANDSCAPING DETAIL

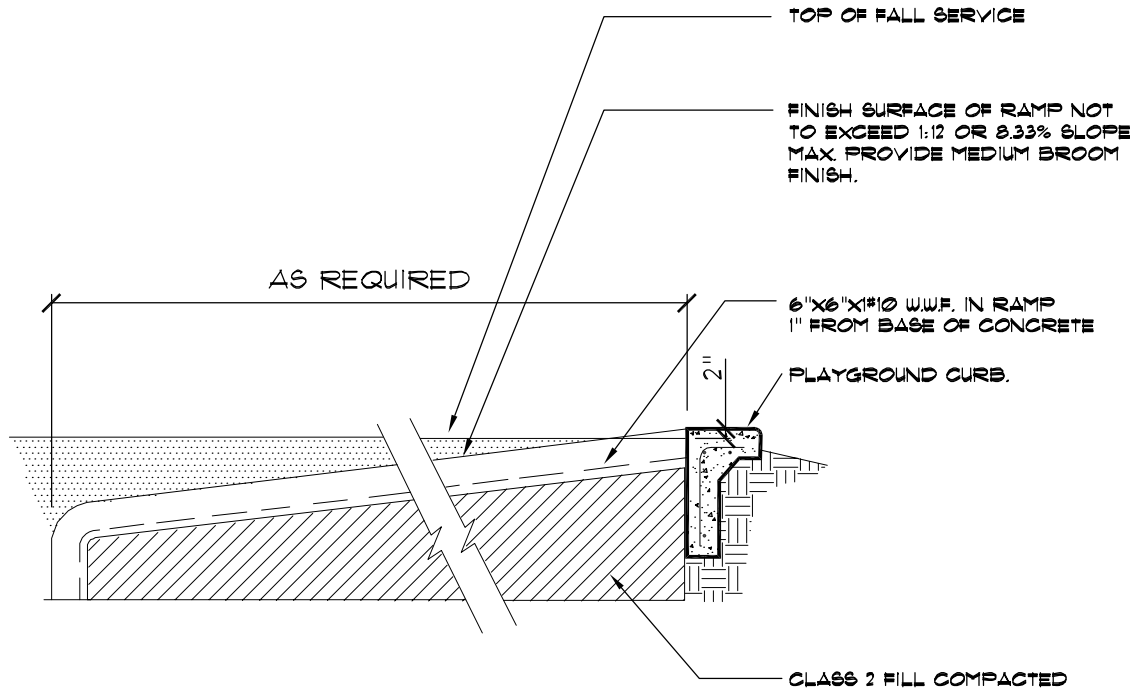

2/08

CITY OF PERRIS  
CITY LANDSCAPE ARCHITECT

*Ron Kammeier*  
RON KAMMEYER

PLAYGROUND RAMP

L-12

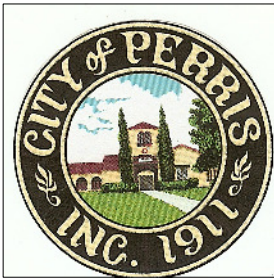

# CITY OF PERRIS

DEVELOPMENT SERVICES DEPARTMENT  
PLANNING DIVISION

135 NORTH "D" STREET, PERRIS, CA. 92570-2200  
TEL: (951) 943-5003 FAX(951) 943-8379

## LANDSCAPING DETAIL

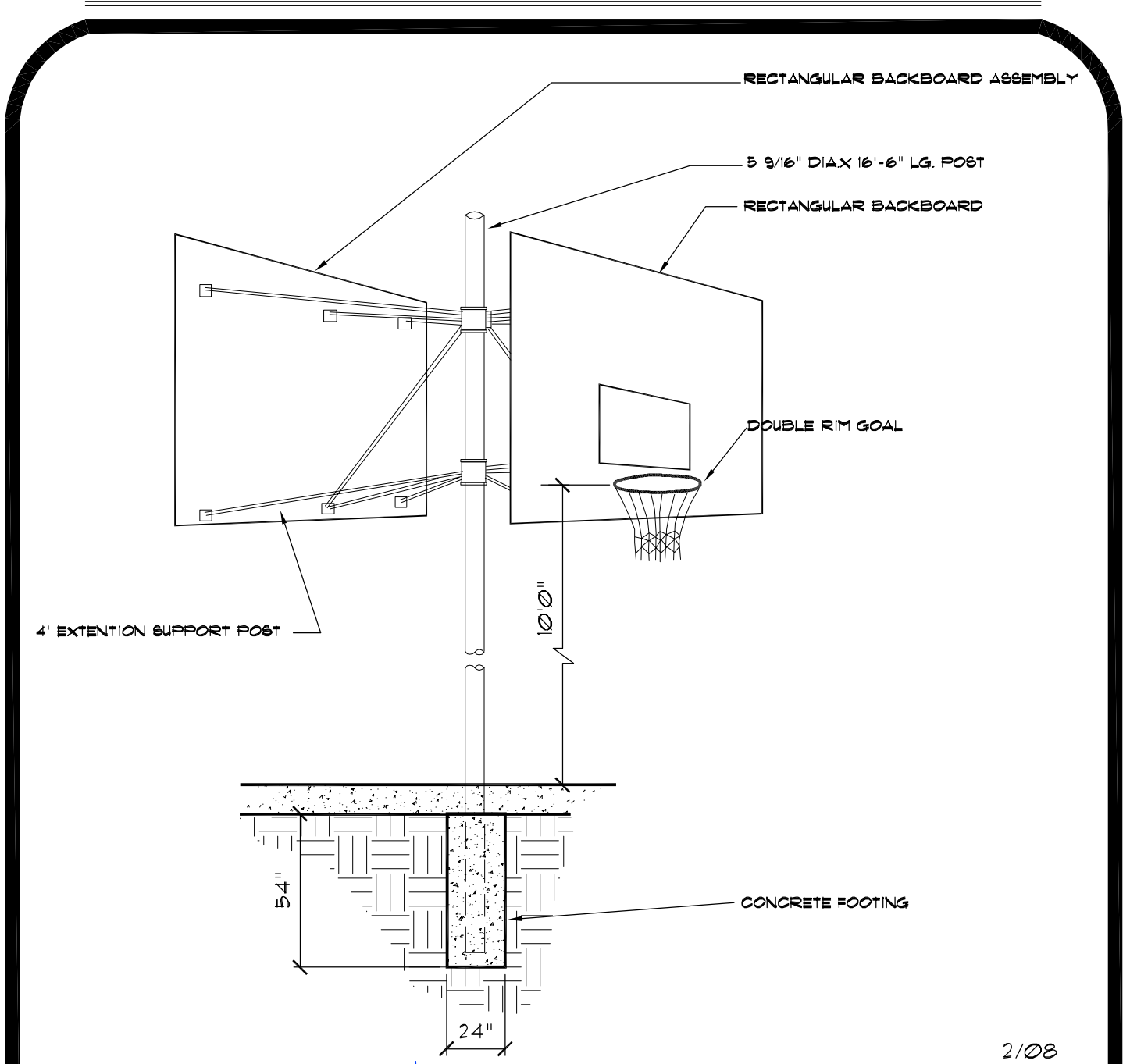

2/08

CITY OF PERRIS  
CITY LANDSCAPE ARCHITECT

*Ron Kammeyer*  
RON KAMMEYER

### BASKETBALL GOAL

### L-13

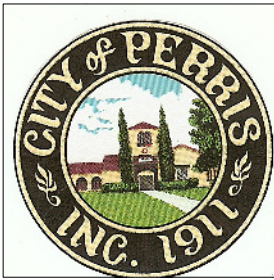

# CITY OF PERRIS

DEVELOPMENT SERVICES DEPARTMENT  
PLANNING DIVISION

135 NORTH "D" STREET, PERRIS, CA. 92570-2200  
TEL: (951) 943-5003 FAX(951) 943-8379

## LANDSCAPING DETAIL

### NOTES

1. ALL WALLS SHALL BE ANTI-GRAFFITI COATED

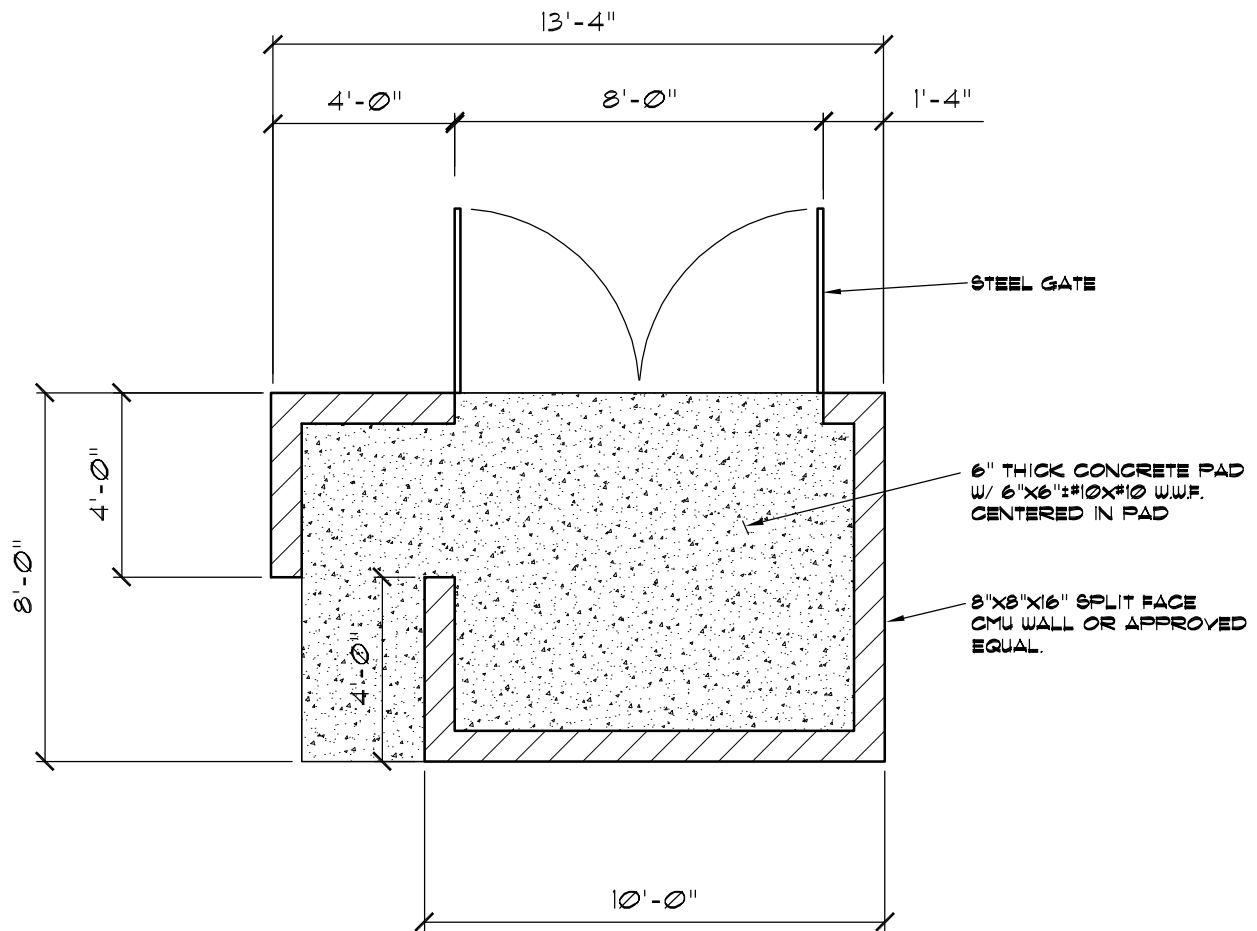

PLAN VIEW

2/08

CITY OF PERRIS  
CITY LANDSCAPE ARCHITECT

*Ron Kammeier*  
RON KAMMEYER

TRASH ENCLOSURE

L-14

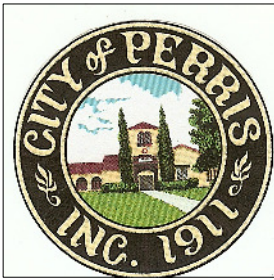

# CITY OF PERRIS

DEVELOPMENT SERVICES DEPARTMENT  
PLANNING DIVISION

135 NORTH "D" STREET, PERRIS, CA. 92570-2200  
TEL: (951) 943-5003 FAX(951) 943-8379

## LANDSCAPING DETAIL

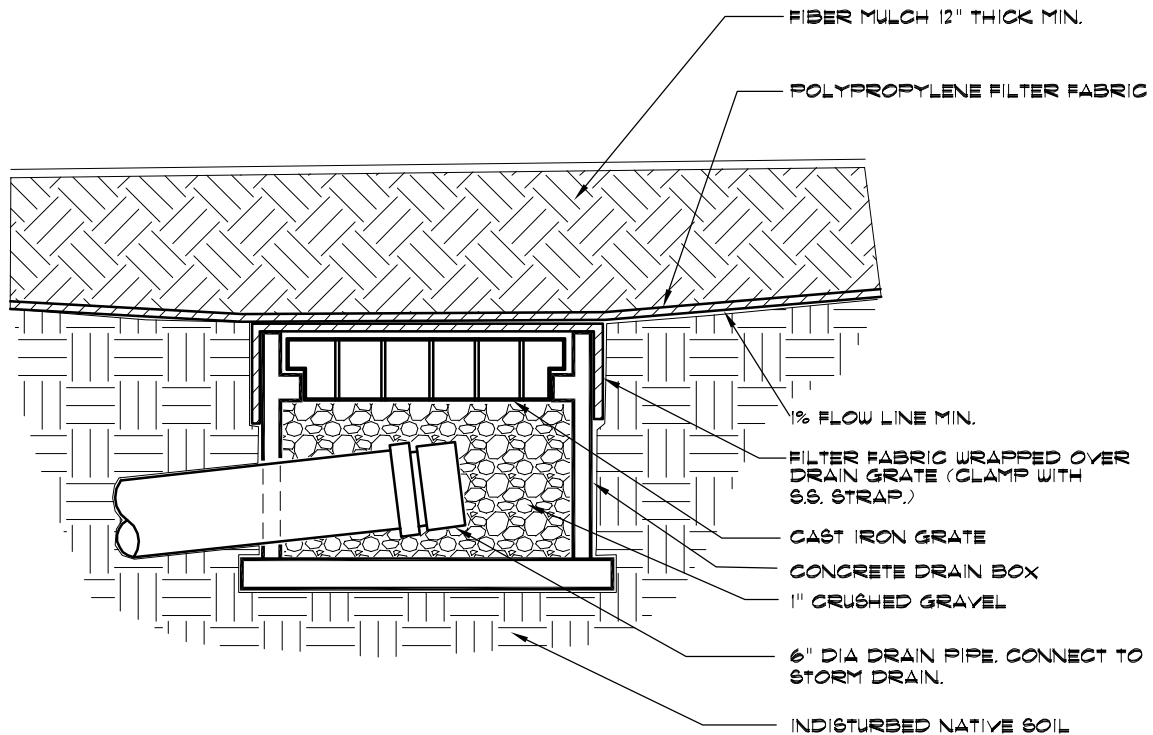

2/08

CITY OF PERRIS  
CITY LANDSCAPE ARCHITECT

*Ron Kamme*  
RON KAMMEYER

### PLAY AREA DRAIN

### L-15

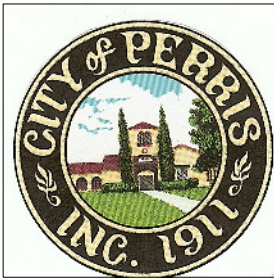

# CITY OF PERRIS

DEVELOPMENT SERVICES DEPARTMENT  
PLANNING DIVISION

135 NORTH "D" STREET, PERRIS, CA. 92570-2200  
TEL: (951) 943-5003 FAX(951) 943-8379

## LANDSCAPING DETAIL

### NOTE

D.G. SAMPLE MUST BE SUBMITTED FOR APPROVAL

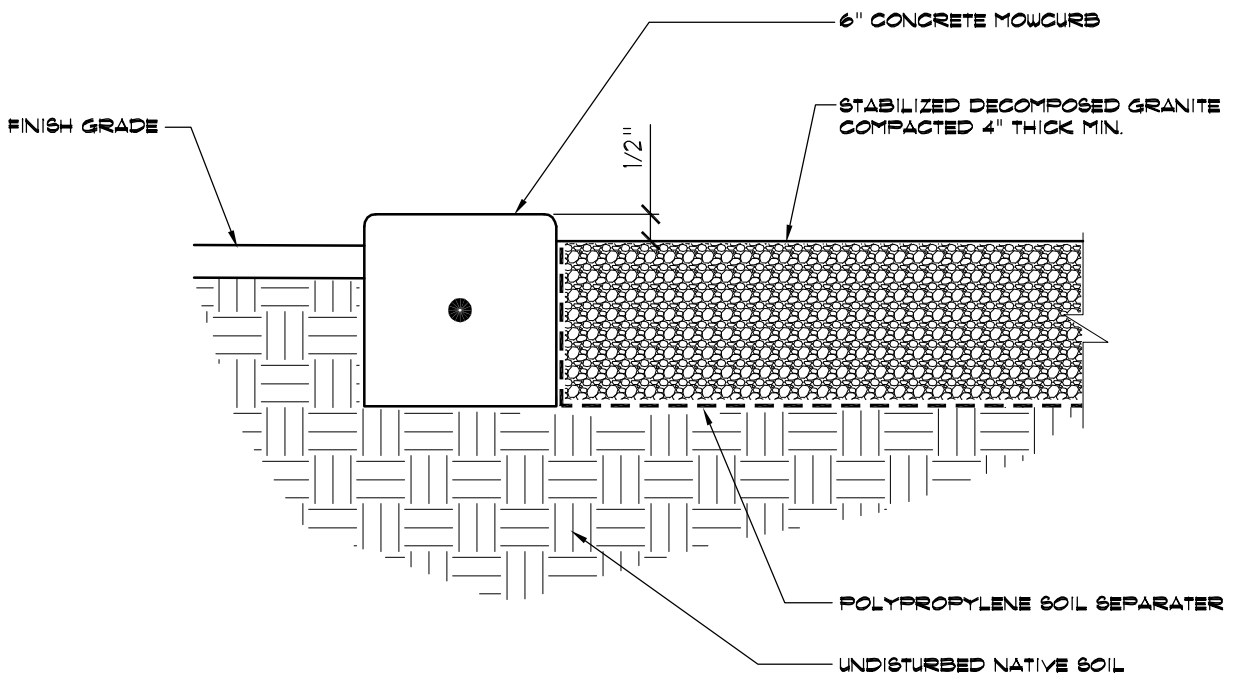

2/08

CITY OF PERRIS  
CITY LANDSCAPE ARCHITECT

*Ron Kammeier*  
RON KAMMEYER

## DECOMPOSED GRANITE PATH

## L-16

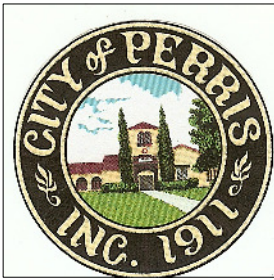

# CITY OF PERRIS

DEVELOPMENT SERVICES DEPARTMENT  
PLANNING DIVISION

135 NORTH "D" STREET, PERRIS, CA. 92570-2200  
TEL: (951) 943-5003 FAX(951) 943-8379

## LANDSCAPING DETAIL

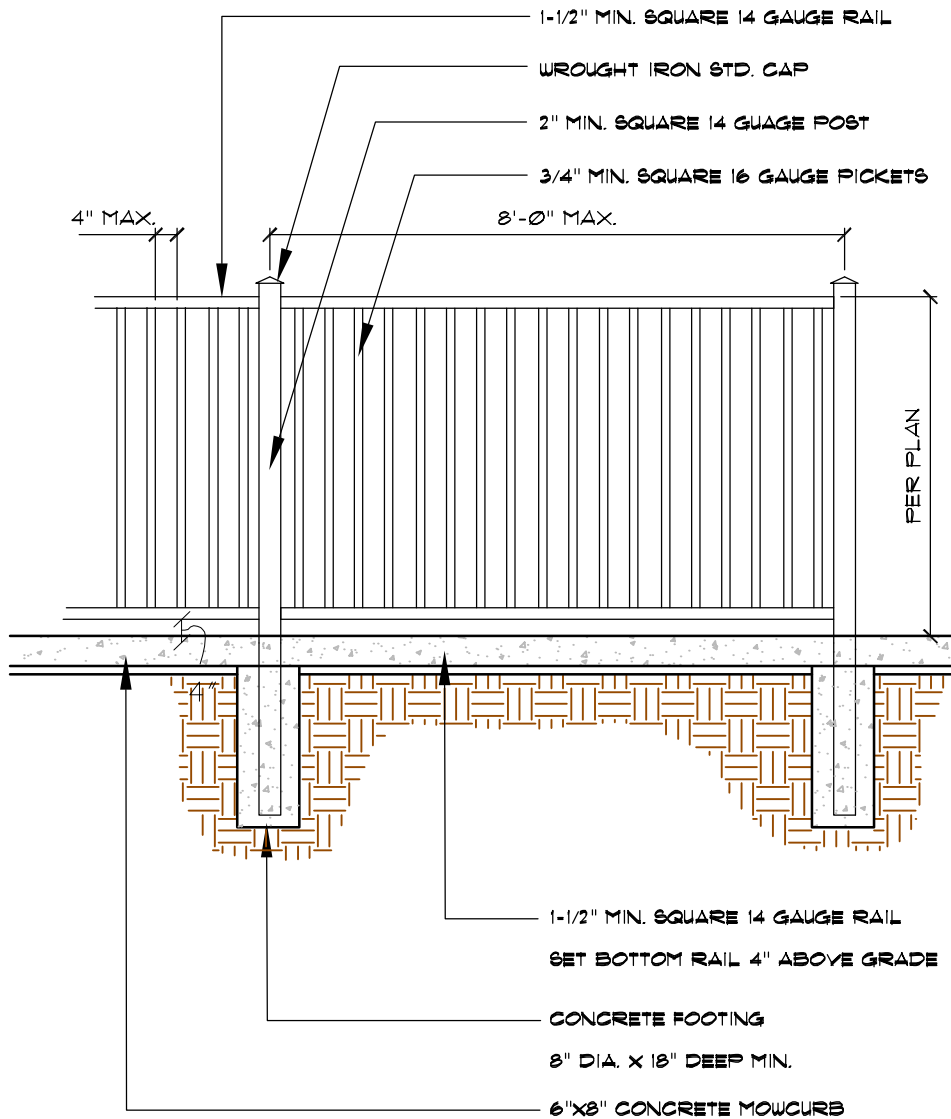

NOTE:  
ALL WELDS SHALL BE GRIND SMOOTH  
POWER WASH WROUGHT IRON PRIOR TO PRIME COAT  
APPLY ONE PRIME COAT & ONE FINISH COAT BLACK ENAMEL  
CONCRETE MOWCURB MUST BE CONTINUOUS BELOW ALL W.I. FENCING TYP.

2/08

CITY OF PERRIS  
CITY LANDSCAPE ARCHITECT

*Ron Kammeier*  
RON KAMMEYER

# WROUGHT IRON FENCING

# L-17



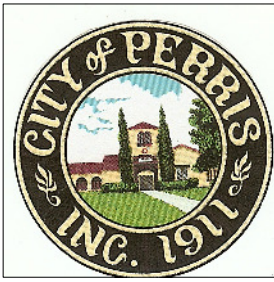

# CITY OF PERRIS

DEVELOPMENT SERVICES DEPARTMENT  
PLANNING DIVISION

135 NORTH "D" STREET, PERRIS, CA. 92570-2200  
TEL: (951) 943-5003 FAX(951) 943-8379

## LANDSCAPING DETAIL

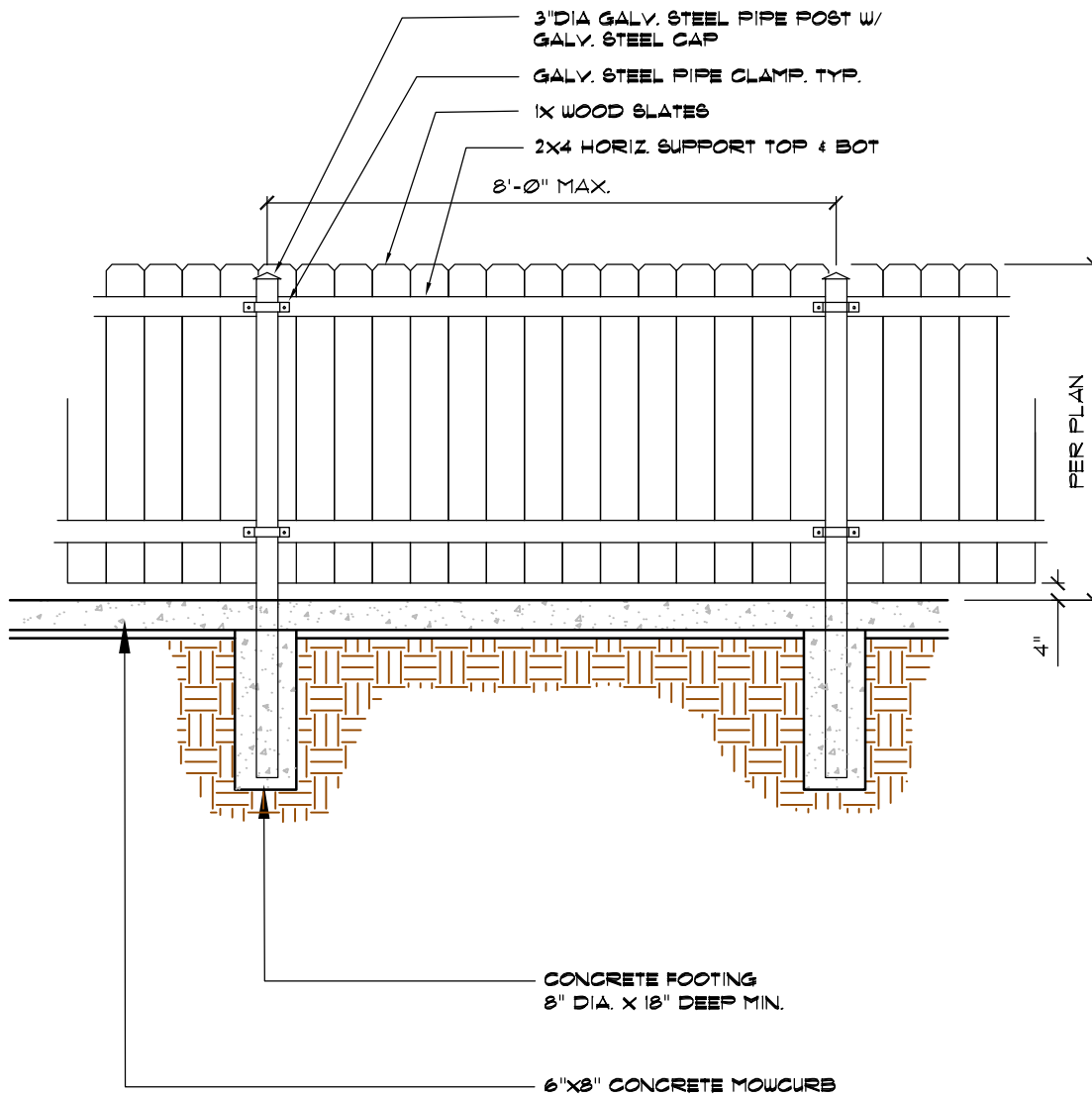

2/08

CITY OF PERRIS  
CITY LANDSCAPE ARCHITECT

*Ron Kammeier*  
RON KAMMEYER

### WOOD FENCING

### L-18

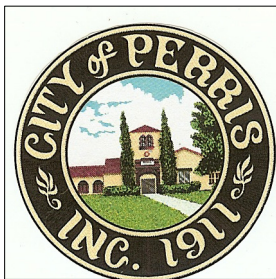

# CITY OF PERRIS

DEVELOPMENT SERVICES DEPARTMENT  
PLANNING DIVISION

135 NORTH "D" STREET, PERRIS, CA. 92570-2200  
TEL: (951) 943-5003 FAX(951) 943-8379

## LANDSCAPING DETAIL

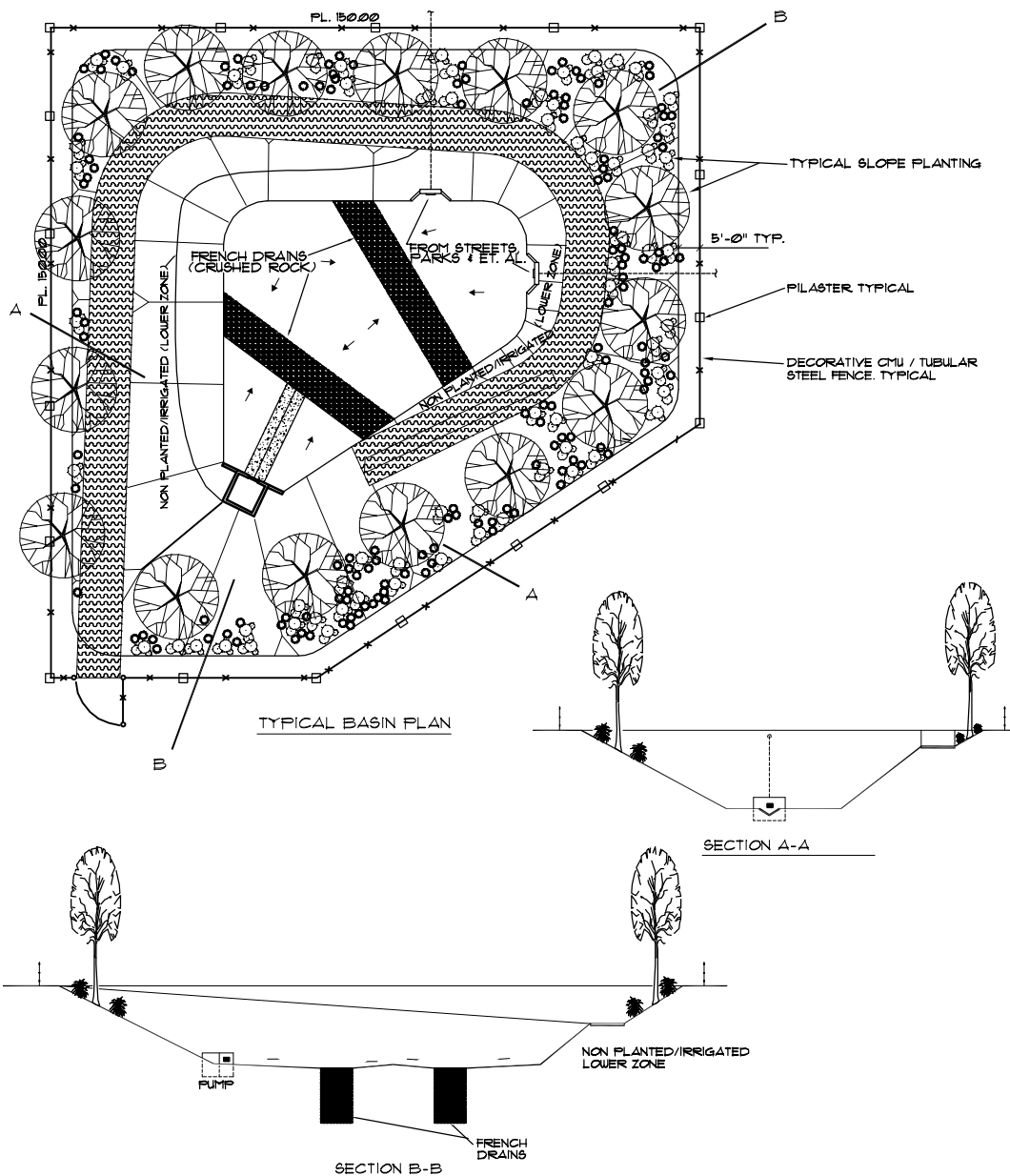

CITY OF PERRIS  
CITY LANDSCAPE ARCHITECT

*Ron Kammeier*  
RON KAMMEYER

# TYPICAL DRAINAGE BASIN

# L-19

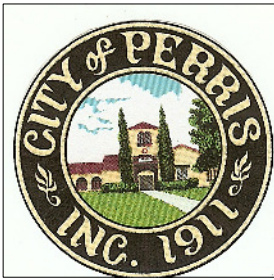

# CITY OF PERRIS

DEVELOPMENT SERVICES DEPARTMENT  
PLANNING DIVISION

135 NORTH "D" STREET, PERRIS, CA. 92570-2200  
TEL: (951) 943-5003 FAX(951) 943-8379

## LANDSCAPING DETAIL

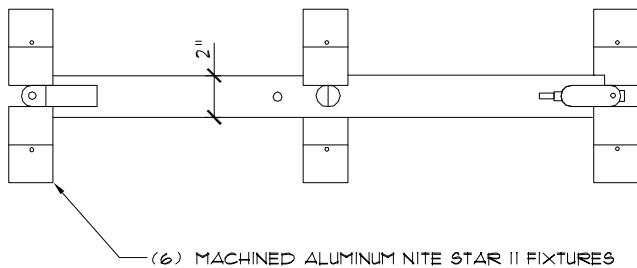
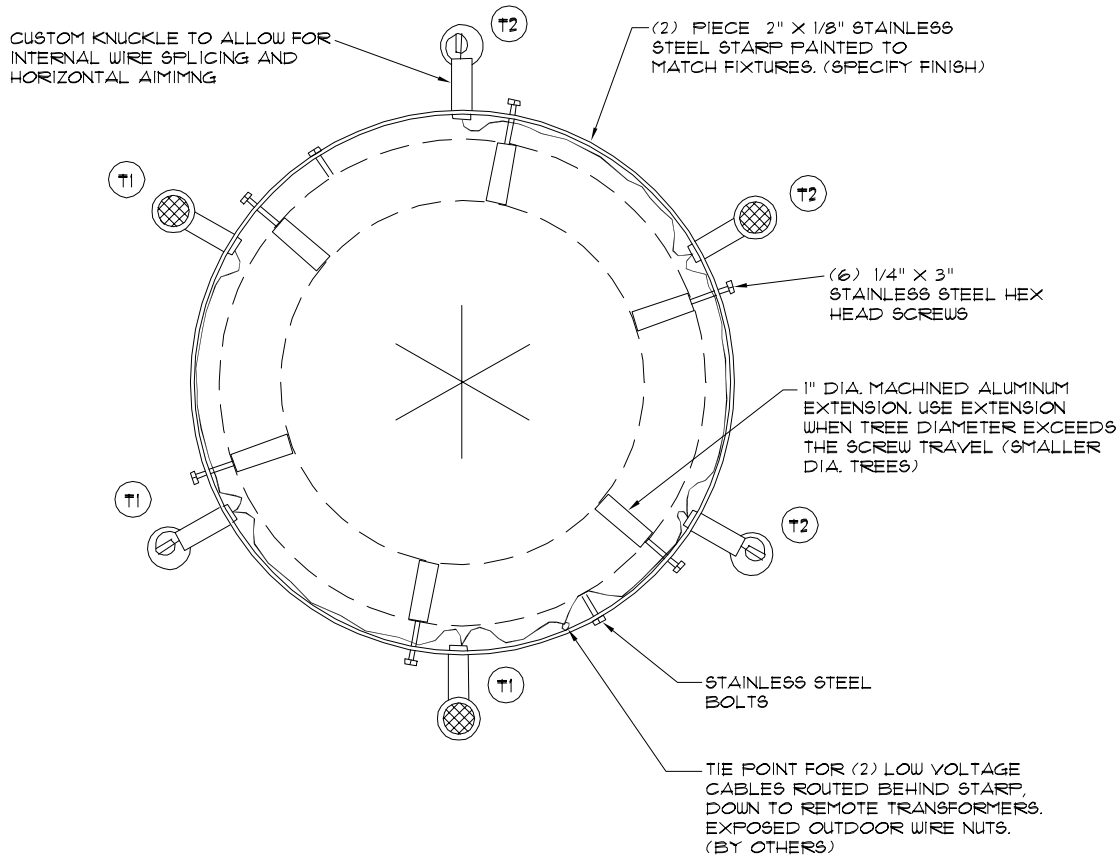

STRAP DIAMETER TABLE

STRAP DIA.	TREE DIA.
25°	15" MIN TO 22" MAX.
30°	21" MIN TO 27" MAX.
35°	26" MIN TO 32" MAX.
40°	31" MIN TO 38" MAX.

2/08

CITY OF PERRIS  
CITY LANDSCAPE ARCHITECT

*Ron Kammeier*  
RON KAMMEYER

# PALM TREE LIGHTING DETAIL

L-20

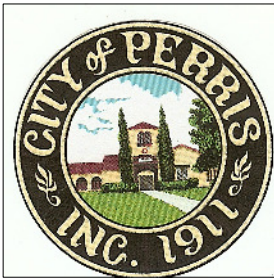

# CITY OF PERRIS

DEVELOPMENT SERVICES DEPARTMENT  
PLANNING DIVISION

135 NORTH "D" STREET, PERRIS, CA. 92570-2200  
TEL: (951) 943-5003 FAX(951) 943-8379

## LANDSCAPING DETAIL

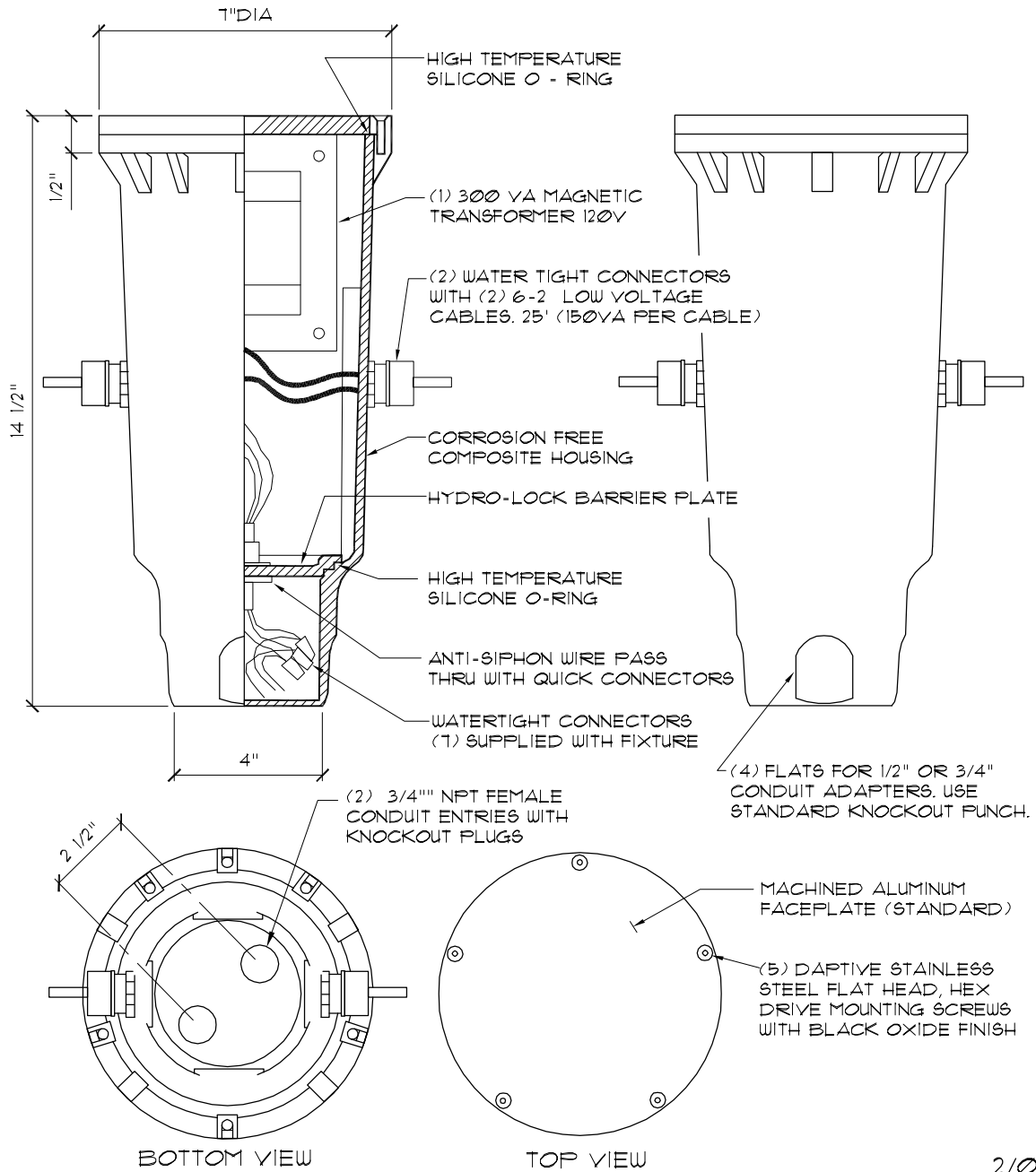

2/08

CITY OF PERRIS  
CITY LANDSCAPE ARCHITECT

*Ron Kammeier*  
RON KAMMEYER

# LIGHTING CONNECTOR DETAIL

# L-21

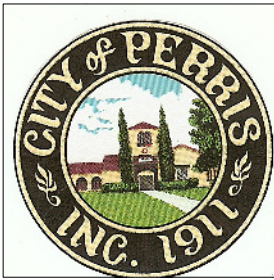

# CITY OF PERRIS

DEVELOPMENT SERVICES DEPARTMENT  
PLANNING DIVISION

135 NORTH "D" STREET, PERRIS, CA. 92570-2200  
TEL: (951) 943-5003 FAX(951) 943-8379

## LANDSCAPING DETAIL

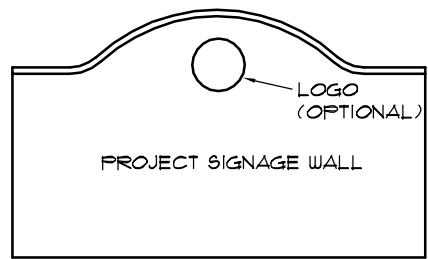
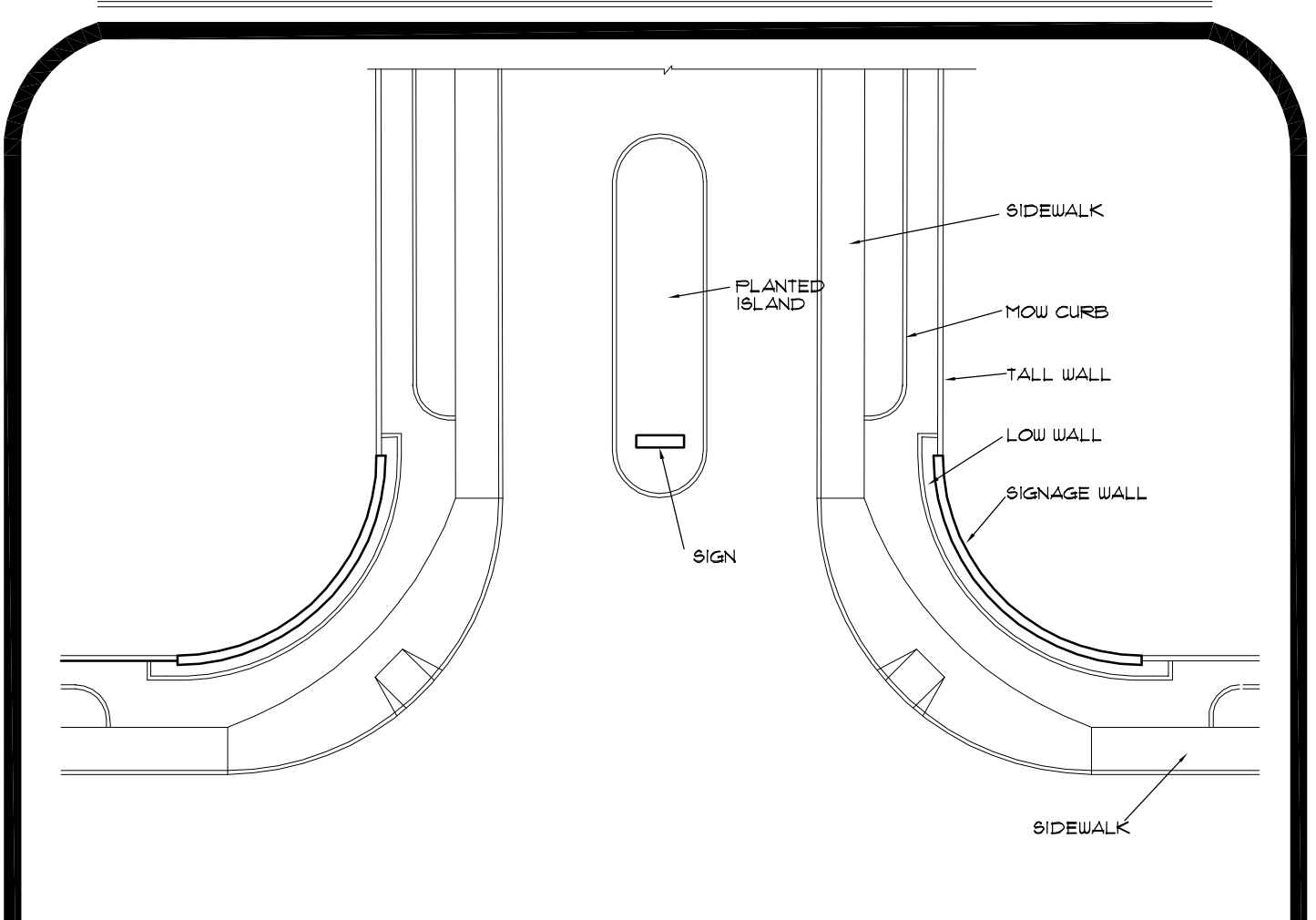

2/08

CITY OF PERRIS  
CITY LANDSCAPE ARCHITECT

*Ron Kammeier*  
RON KAMMEYER

# TYPICAL PROJECT ENTRANCE

# L-22

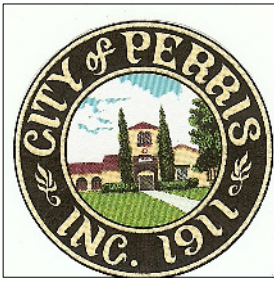

# CITY OF PERRIS

DEVELOPMENT SERVICES DEPARTMENT  
 PLANNING DIVISION

135 NORTH "D" STREET, PERRIS, CA. 92570-2200  
 TEL: (951) 943-5003 FAX(951) 943-8379

## LANDSCAPING DETAIL

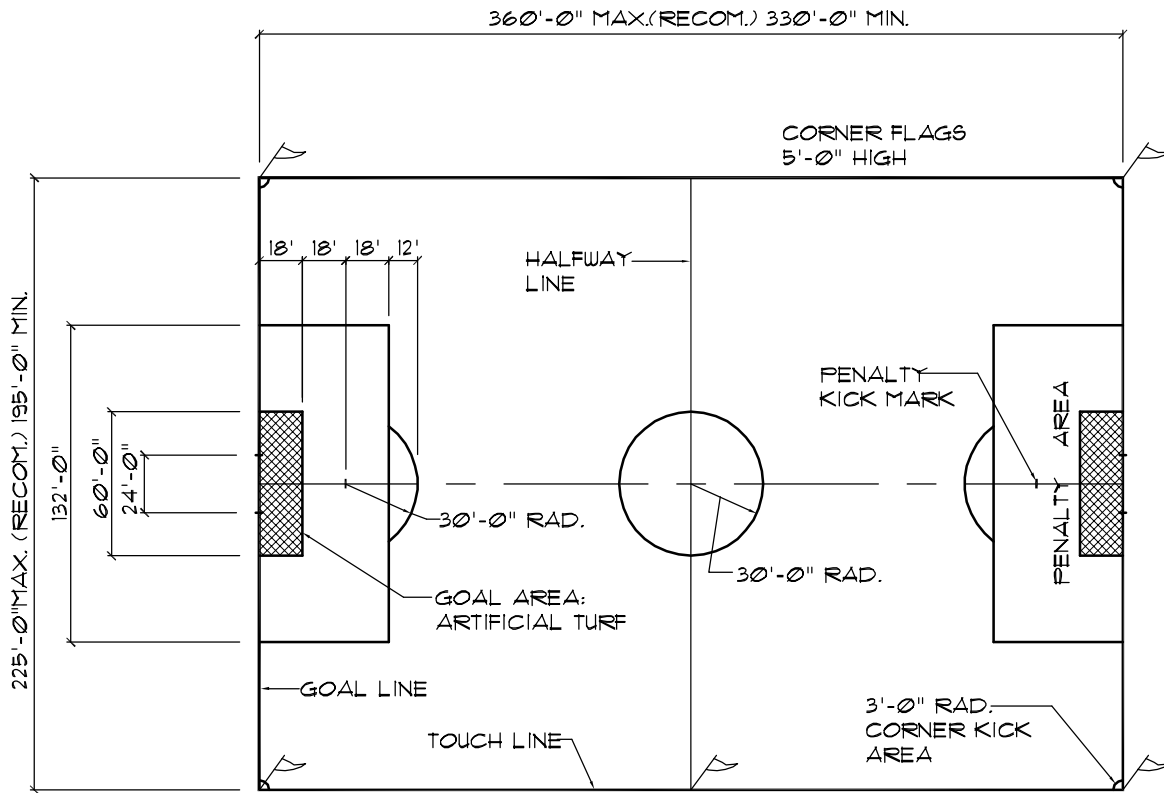

2/08

CITY OF PERRIS  
 CITY LANDSCAPE ARCHITECT

*Ron Kammeier*  
 RON KAMMEYER

**SOCCER FIELD**

AMERICAN SOCCER LEAGUE  
 N. AMERICAN SOCCER LEAGUE  
 NCAA = SOCCER RULES

**L-23**

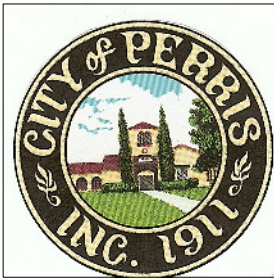

# CITY OF PERRIS

## DEVELOPMENT SERVICES DEPARTMENT PLANNING DIVISION

135 NORTH "D" STREET, PERRIS, CA. 92570-2200  
TEL: (951) 943-5003 FAX(951) 943-8379

### LANDSCAPING DETAIL

1. 4" - 6" SALT & PEPPER GRANITE ROCKS
2. DECOMPOSED GRANITE (DG) FILLER "CALIFORNIA GOLD", COMPACTED.
3. ADJUST EXISTING SOIL DEPTH.
4. 2" MIN. DEPTH SAND. COMPACT WITH VIBER PLATE OR EQUAL.
5. EXISTING SOIL. COMPACT TO 90% MIN. OR PER SOILS REPORT.
6. MEDIAN CURB

#### SCOPE OF WORK:

- REMOVE EXISTING SOIL AS SHOWN.
- RECOMPACT REMAINING SOIL
- INSTALL SAND AND COMPACT
- INSTALL GRANITE ROCKS & PACK
- INSTALL DECOMPOSED GRANITE BETWEEN ROCKS, FILLING IN VOIDS.

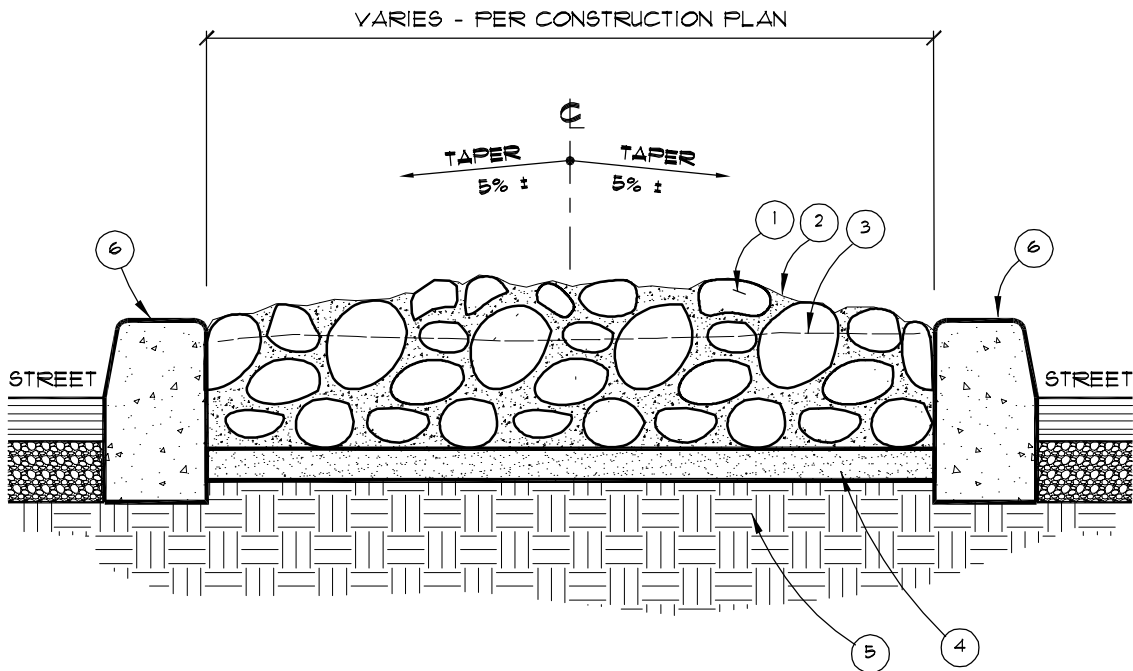

CITY OF PERRIS  
CITY LANDSCAPE ARCHITECT

*Ron Kammeier*  
RON KAMMEYER

12/09

TEMPORARY STREET  
MEDIAN (GRANITE ROCK)

L-24



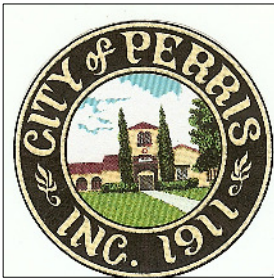

# CITY OF PERRIS

DEVELOPMENT SERVICES DEPARTMENT  
PLANNING DIVISION

135 NORTH "D" STREET, PERRIS, CA. 92570-2200  
TEL: (951) 943-5003 FAX(951) 943-8379

## LANDSCAPING DETAIL

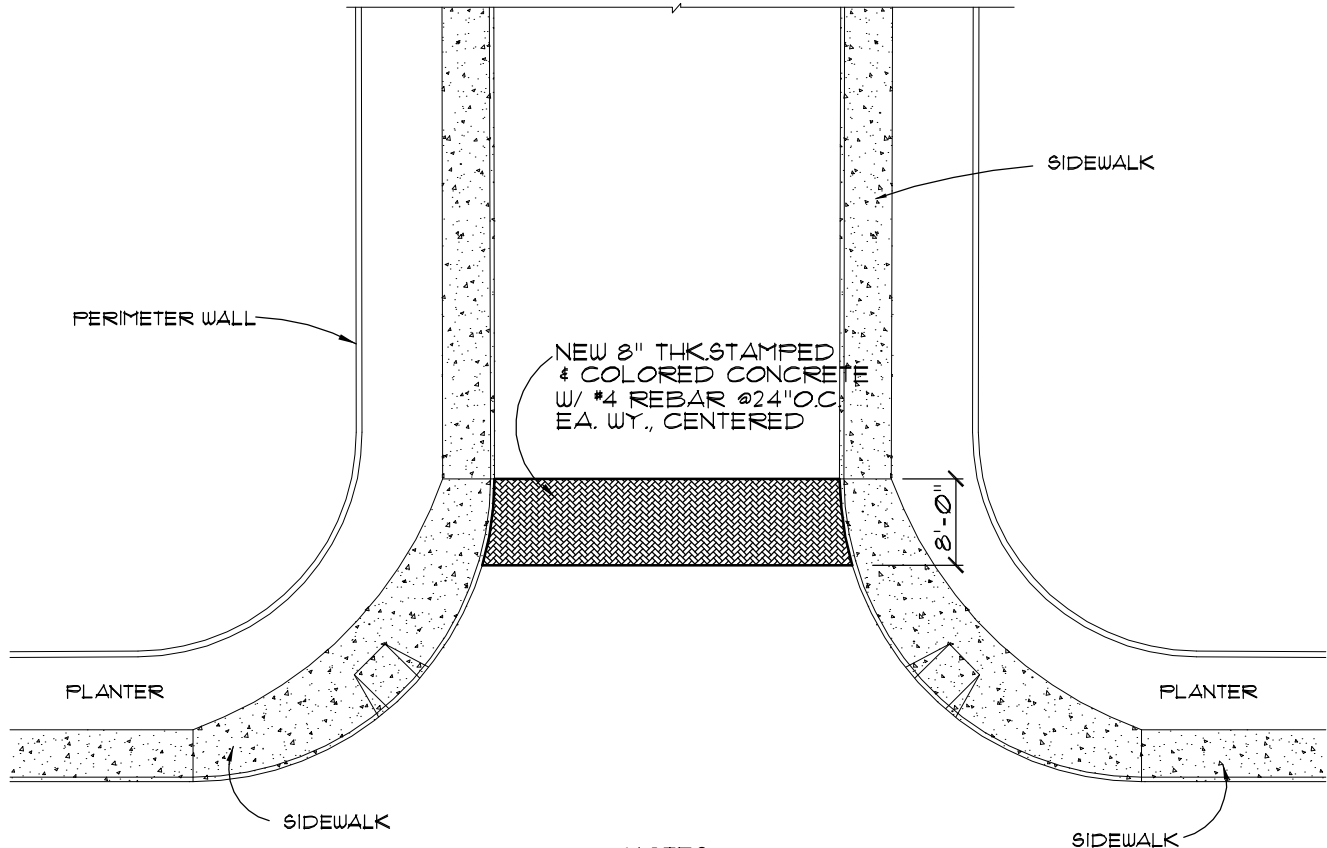

### NOTES:

1. CONCRETE SHALL BE 2500 PSI MIN., @ 28 DAYS.
2. RECOMPACT SUBGRADE TO 90% MIN. OR PER SOILS REPORT.
3. COLOR BY CITY LANDSCAPE ARCHITECT DAVIS, SCOUFIELD OR EQ.
4. STAMPED CONCRETE PATTERN TO BE HERRING BONE, 4X8 BRICK SOLDER COURSE OR APPROVED.

CITY OF PERRIS  
CITY LANDSCAPE ARCHITECT

*Ron Kammeier*  
RON KAMMEYER

12/09

**PROJECT ENTRANCE  
(STAMPED CONCRETE)**

**L-25**



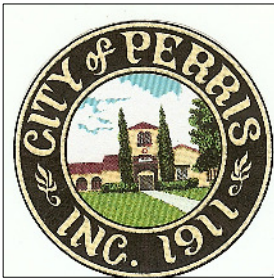

# CITY OF PERRIS

DEVELOPMENT SERVICES DEPARTMENT  
PLANNING DIVISION

135 NORTH "D" STREET, PERRIS, CA. 92570-2200  
TEL: (951) 943-5003 FAX(951) 943-8379

## LANDSCAPING DETAIL

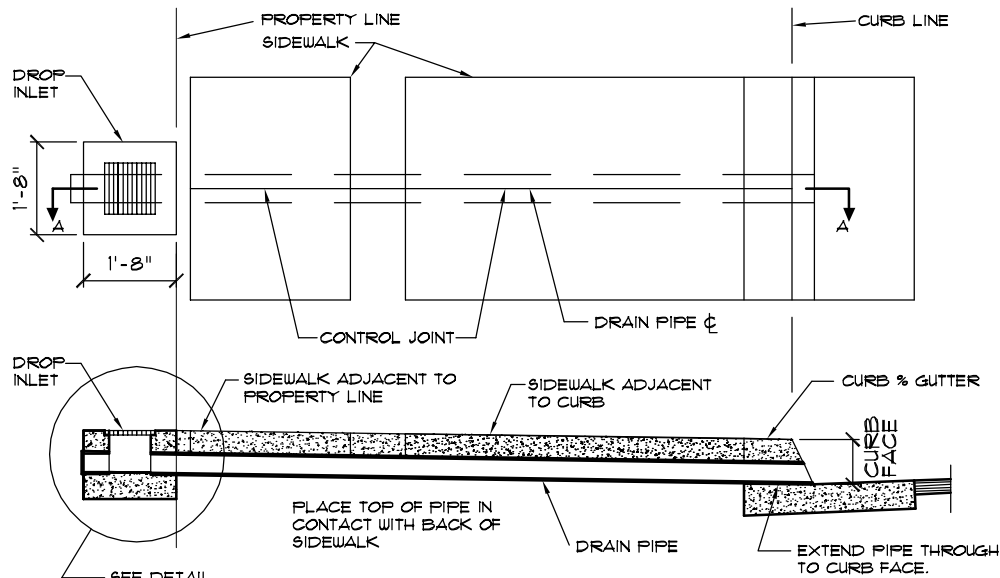

SECTION A-A

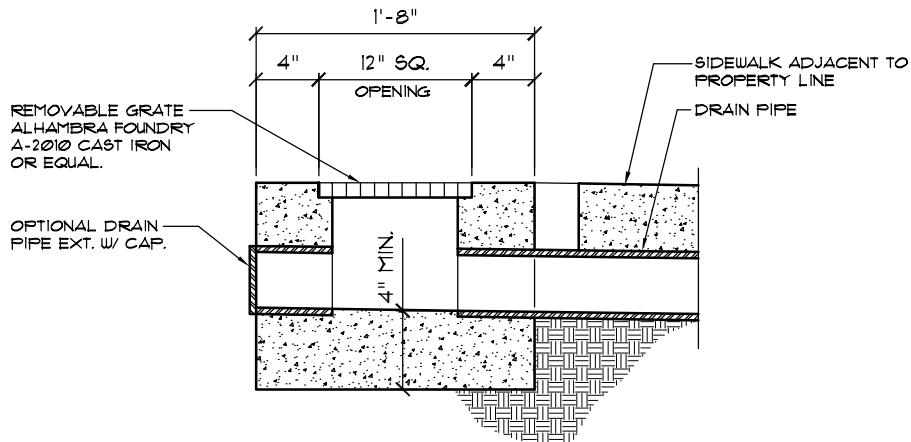

DROP INLET DETAIL

### NOTES

1. THIS STANDARD SHALL BE USED WHERE CURB & SIDEWALK ARE EXISTING
2. CURB DRAIN SHALL BE CONSTRUCTED BY BORING THROUGH CURB FACE.
3. DRAIN PIPE SHALL BE CIRCULAR ASBESTOS CEMENT OR RIGID PLASTIC, WITH AN INSIDE DIAMETER OF 3" OR 6" CURB & 4" FOR 8" CURB FACE.
4. DROP INLET MAY BE AN APPROVED PREFABRICATED DESIGN OR CONSTRUCTED ON-SITE. A TEE OR ELBOW, WITH A REMOVABLE GRATE-TYPE CAP, ENCASED IN CONCRETE, IS AN ACCEPTABLE ALTERNATE.

CITY OF PERRIS  
CITY LANDSCAPE ARCHITECT

*Ron Kammeier*  
RON KAMMEYER

**UNDER SIDEWALK DRAIN  
EXISTING CONSTRUCTION**

**L-26**

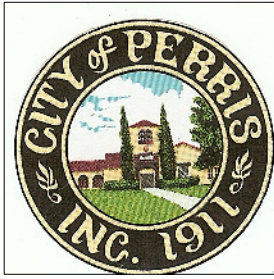

# CITY OF PERRIS

DEVELOPMENT SERVICES DEPARTMENT  
 PLANNING DIVISION

135 NORTH "D" STREET, PERRIS, CA. 92570-2200  
 TEL: (951) 943-5003 FAX(951) 943-8379

## LANDSCAPING DETAIL

### NOTES

1. ROOT PRUNE ROOTS OVER 1" DIAMETER.
2. ADJUST IN THE FIELD PER CITY LANDSCAPE ARCHITECT.
3. CMU TO BE ALLAN BLOCK CORPORATION - 5300 EDINA INDUSTRIAL BLYD MN. 952-835-5309 OR APPROVED EQUAL.
4. INSTALL CMU RETAINING WALL PER MANUFACTURERS SPECIFICATIONS.

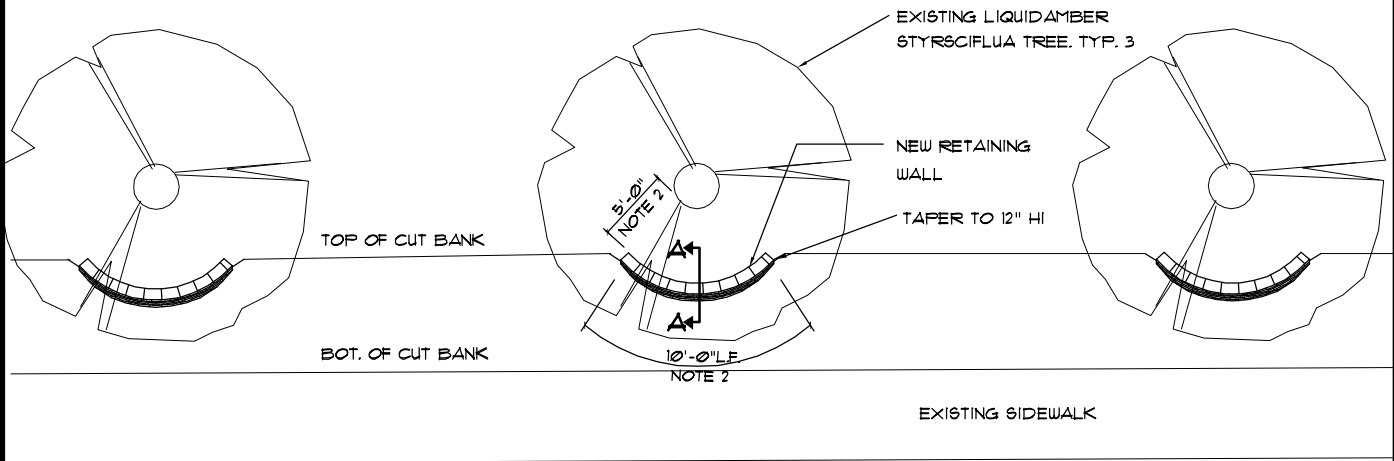

### PLAN VIEW NTS

EXISTING STREET

NEW ASHLAR BLEND  
 MORTARLESS CMU  
 BY ALLAN BLOCK  
 OR APPROVED EQ.  
 FILLED SOLID W/  
 GROUT. NOTE 3

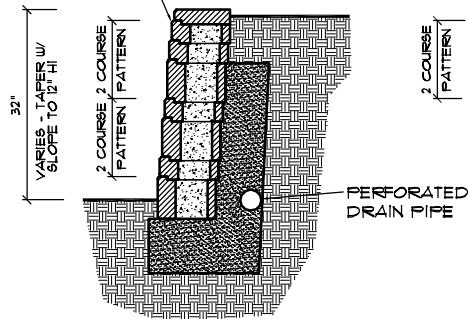

### RETAINING WALL SECTION A-A NTS

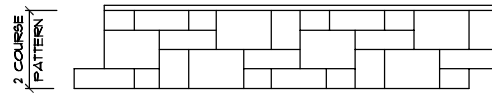

### COURSE ELEVATION NTS

CITY OF PERRIS  
 CITY LANDSCAPE ARCHITECT

*Ron Kammeier*  
 RON KAMMEYER

## CRIB WALL DETAIL

L-27